

FEATURES

- Plastic package has Underwriters Laboratory Flammability Classification 94V-0
- Bilateral voltage triggered
- AC circuit oriented
- Glass-passivated junctions
- High surge current capabilities
- High voltage lamp ignitors
- Xenon ignitors
- Natural gas ignitors
- Over voltage protector
- High temperature soldering guaranteed:260°C/10 seconds at terminals
- Component in accordance to RoHS 2011/65/EU

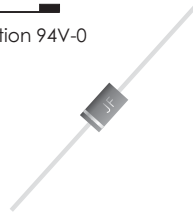

DO-15

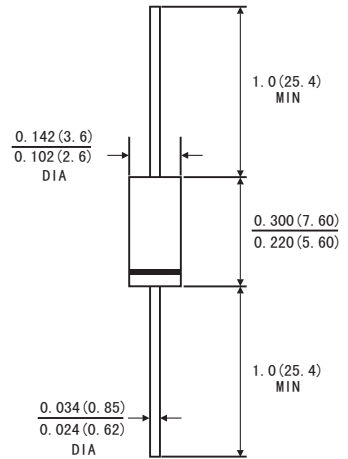

MECHANICAL DATA

- Case: JEDEC DO-15 molded plastic body
- Terminals: Plated axial leads, solderable per MIL-STD-750,method 2026

MAXIMUM RATINGS AND ELECTRICAL CHARACTERISTICS

(Ratings at 25°C ambient temperature unless otherwise specified ,Single phase ,half wave ,resistive or inductive load. For capacitive load, derate by 20%.)

	Symbols	DB260B	Units
Repetitive Peak Off-state Voltage	V_{DRM}	± 190	Volts
Breakover Current 50/60 Hz sine wave	I_{BO}	10	μA
Repetive peak off-state current, 50/60Hz sine wave	I_{DRM}	10	μA
Maximum on-state RMS current, $T_J \leq 110^\circ C$ 50/60Hz sine wave	$I_{T(RMS)}$	0.6	Amp
Breakover voltage 50/60Hz sine wave	MIN	240	Volts
	MAX	270	
Maximum dynamic holding current 50/60Hz sine wave $R=100\Omega$	I_H	100	mA
Peak one cycle surge current sine wave (non-repetitive)	50Hz	16.7	A
	60Hz	20	
Typical peak on-state voltage($I_T=0.6A$)	V_{TM}	1.5	Volts
Switching resistance ($V_{BO}-V_S$)/(I_S-I_{BO}) 60Hzsine wave	R_s	0.1	$k\Omega$
Operating temperature range	T_J	-40 to +110	$^\circ C$
Operating junction and storage temperature range	T_{STG}	-55 to +150	$^\circ C$

RATINGS AND CHARACTERISTIC CURVES DB260B

V-I Characteristics

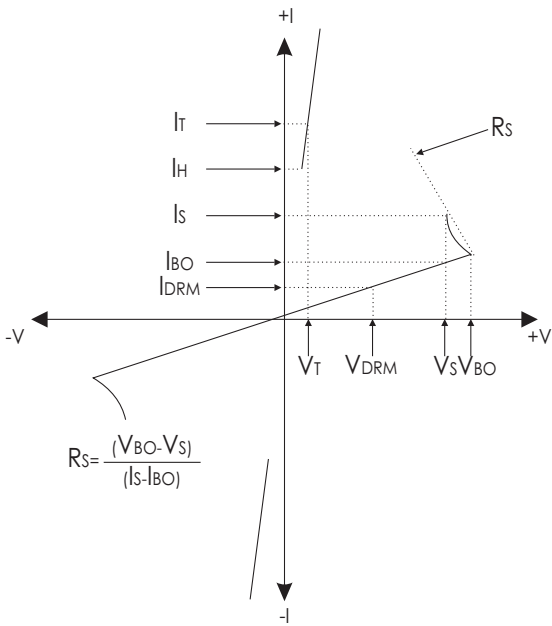

FIG.1 Normalized DC Holding Current vs case/Lead Temperature

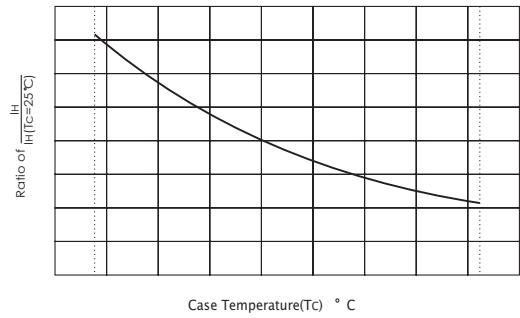
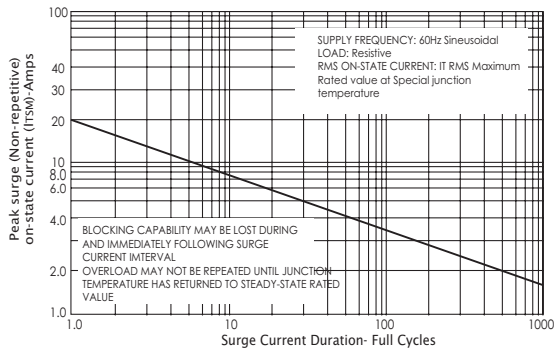

FIG.2 Peak surge current vs surge current duration



RATINGS AND CHARACTERISTIC CURVES DB260B

FIG.3 Maximum Allowable Ambient temperature vs on-state Current

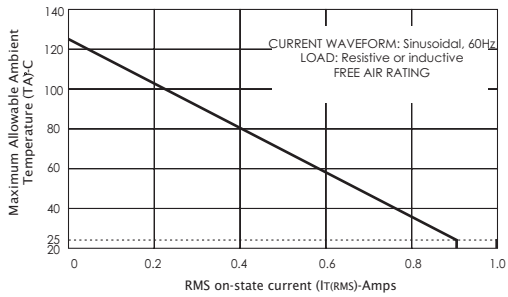

FIG.4 Normalized Repetitive Peak Breakover Current vs Junction Temperature

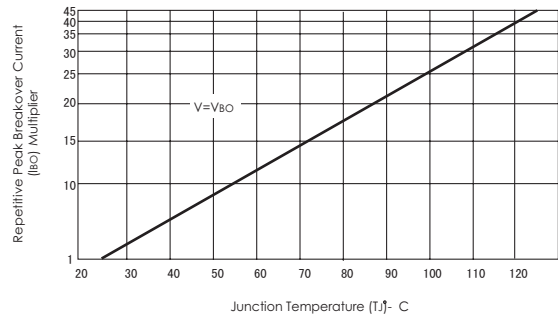

FIG.5 Normalized C_{BO} Changes vs Case Temperature

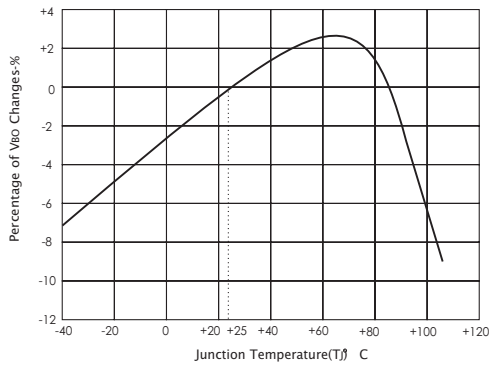

FIG.6 Repetitive Peak On-State Current (I_{TRM}) vs Pulse Width at Various Frequencies

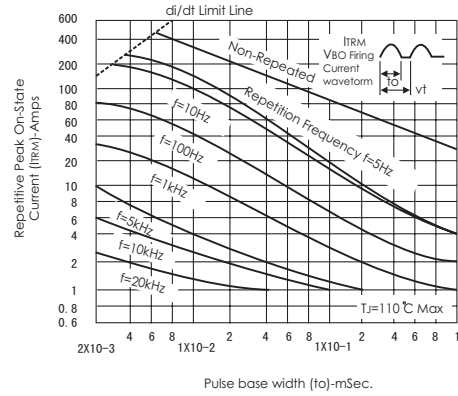

FIG.7 On-State Current vs On-State Voltage

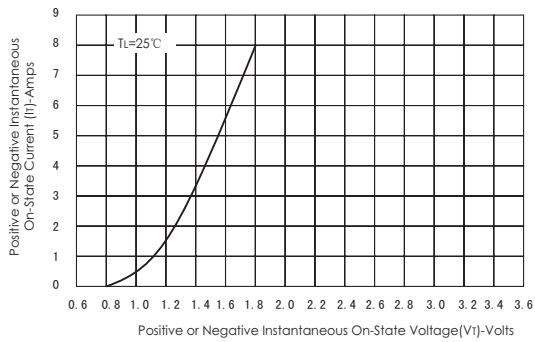
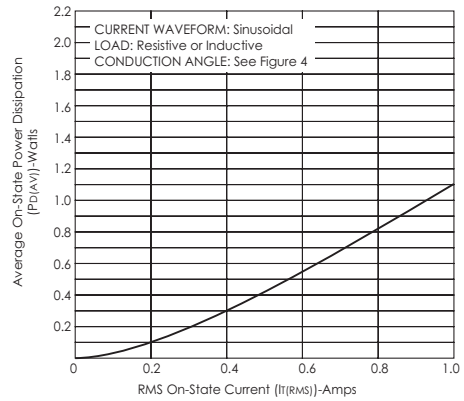

FIG.8 Power Dissipation (Typical) vs On-State Current



RATINGS AND CHARACTERISTIC CURVES DB260B

FIG.9 Ignitor Circuit (Low Voltage Input)

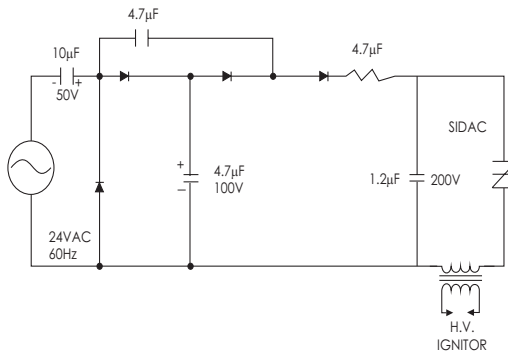

FIG.10 Typical High Pressure Sodium Lamp Firing Circuit

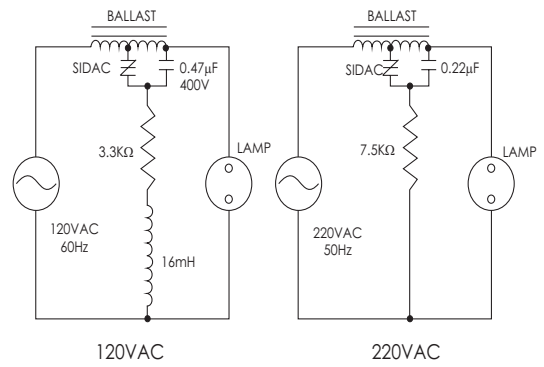

FIG.11 Comparison of SIDAC vs SCR

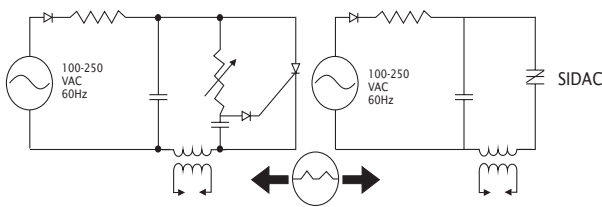

FIG.12 Xenon Lamp Flashing Circuit

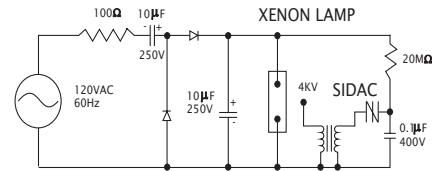
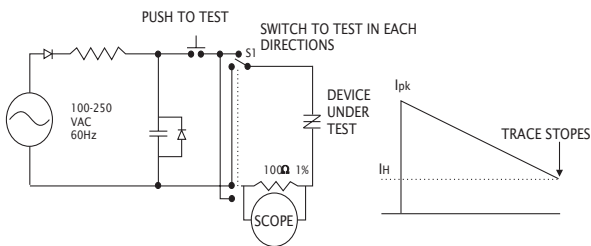
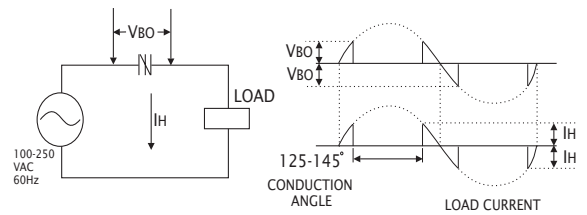

FIG.13 Dynamic Holding Current Test Circuit for SIDAC



JINAN JINGHENG ELECTRONICS CO., LTD.

FIG.14 Basic SIDAC Circuit



RATINGS AND CHARACTERISTIC CURVES DB260B

FIG.15 Relaxation Oscillator Using a SIDAC

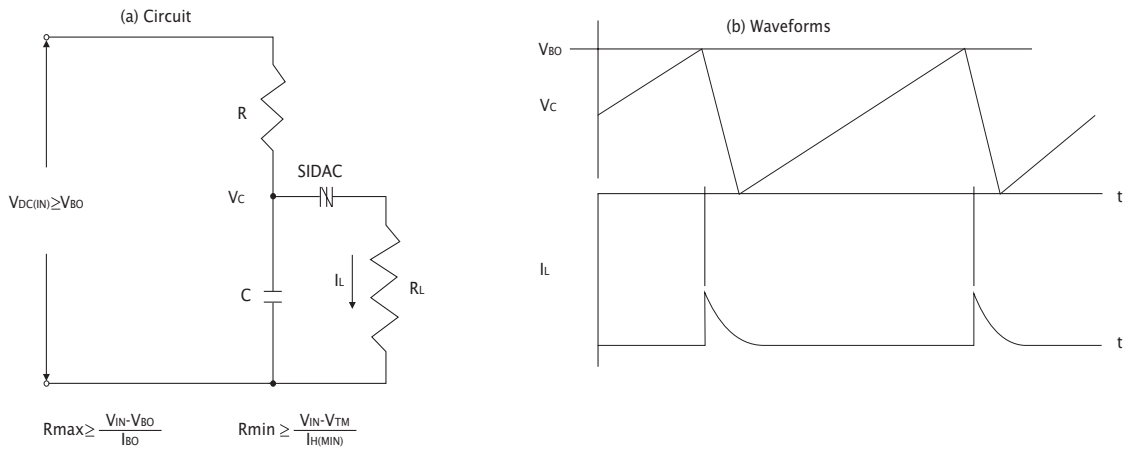
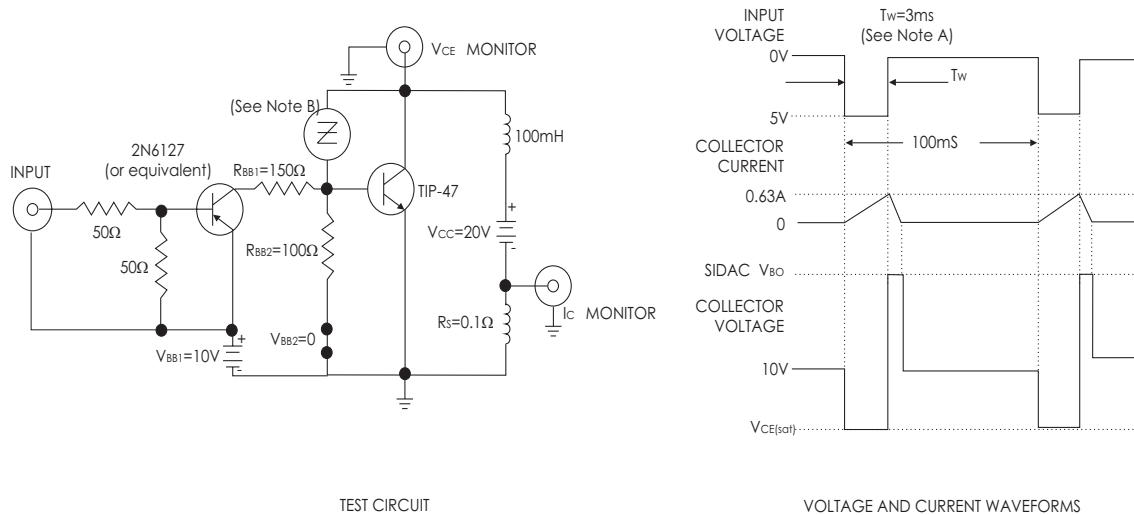

FIG.16 SIDAC Added To Protect Transistor For Typical Transistor Inductive Load Switching Requirements



NOTE A: Input pulse width is increased until $I_{Cv}=0.63A$.

NOTE B: Sidac (or Diac or series of diacs) chosen so that V_{BO} is just below V_{CE0} rating of transistor to be protected. The Sidac (or Diac) eliminates a reverse breakdown of the transistor in inductive switching circuits where otherwise the transistor could be destroyed.