

### FEATURES

- Plastic package has Underwriters Laboratory Flammability Classification 94V-0
- Metal silicon junction ,majority carrier conduction
- Guard ring for overvoltage protection
- Low power loss ,high efficiency
- High current capability ,low forward voltage drop
- High surge capability
- High temperature soldering guaranteed:260°C/10 seconds at terminals
- Component in accordance to RoHS 2011/65/EU

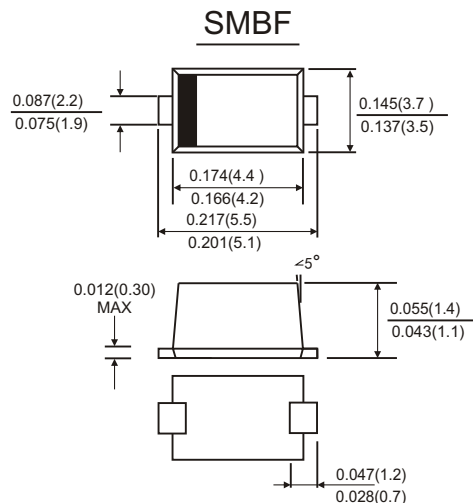

Dimensions in inches and (millimeters)

### MECHANICAL DATA

- Case: SMBF molded plastic body
- Terminals: Solder Plated, solderable per MIL-STD-750,method 2026
- Polarity: Color band denotes cathode end
- Weight: 0.003ounce, 0.093 gram

### TYPICAL APPLICATIONS

For use in low voltage ,high frequency inverters ,DC/DC converters, free wheeling ,and polarity protection applications

### MAXIMUM RATINGS

(Ratings at 25°C ambient temperature unless otherwise specified )

Parameter	Symbol	Value	Unit
Maximum repetitive peak reverse voltage	$V_{RRM}$	60	V
Maximum average forward rectified current (see fig.1)	$I_{F(AV)}$	3.0	A
Peak forward surge current 8.3ms single half sine-wave superimposed on rated load (JEDEC method at rated TL)	$I_{FSM}$	80	A
Operating junction temperature range	$T_J$	-55 to+150	°C
Storage temperature range	$T_{stg}$	-55 to+150	°C

# RATINGS AND CHARACTERISTIC OF SS36LBT

## ELECTRICAL CHARACTERISTICS ( $T_A=25^{\circ}\text{C}$ Unless otherwise noted)

Parameter	Test Conditions		Symbol	TYP.	MAX.	Unit
Instantaneous forward voltage	$I_F=3.0\text{A}$	$T_A=25^{\circ}\text{C}$	$V_F$ <sup>1)</sup>	0.53	0.55	V
		$T_A=100^{\circ}\text{C}$		0.47	0.49	
		$T_A=125^{\circ}\text{C}$		0.45	0.47	
Reverse current	$V_R=60\text{V}$	$T_A=25^{\circ}\text{C}$	$I_R$ <sup>2)</sup>	60	150	$\mu\text{A}$
		$T_A=100^{\circ}\text{C}$		5	10	mA
		$T_A=125^{\circ}\text{C}$		15	30	
Typical junction capacitance	4V, 1MHz		$C_J$	240		pF

Notes: 1.Pulse test: 300  $\mu\text{s}$  pulse width, 1% duty cycle

2.Pulse test: pulse width $\leq$ 40ms

## THERMAL CHARACTERISTICS

Parameter	Symbol	SMBF	Unit
Typical thermal resistance <sup>3)</sup>	$R_{\theta JA}$	70.0	$^{\circ}\text{C/W}$
	$R_{\theta JL}$	25.0	

3. Unit mounted on PC board with 5.0mm $\times$ 5.0 mm (0.013 mm thick) copper pads as heat sink

## AVAILABLE PACK INFORMATION

Product code	Pack	Reel Size (mm)	Quantity (pcs/reel)	Box Size L $\times$ W $\times$ H (mm)	Quantity (reel/box)	Carton Size L $\times$ W $\times$ H (mm)	Quantity (box/carton)
SS36LBT-SMBF	T/R	$\Phi$ 300	3000	340 $\times$ 340 $\times$ 40	2	370 $\times$ 370 $\times$ 370	8

# RATINGS AND CHARACTERISTIC OF SS36LBT

FIG.1-FORWARD CURRENT DERATING CURVE

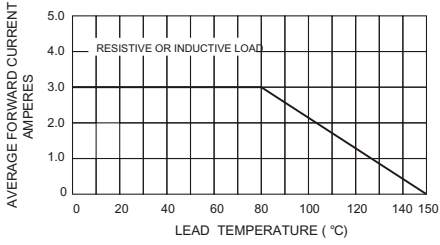

FIG.2-MAXIMUM NON-REPETITIVE PEAK FORWARD SURGE CURRENT

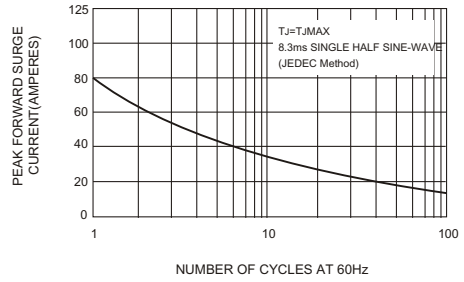

FIG.3-TYPICAL INSTANTANEOUS FORWARD CHARACTERISTICS

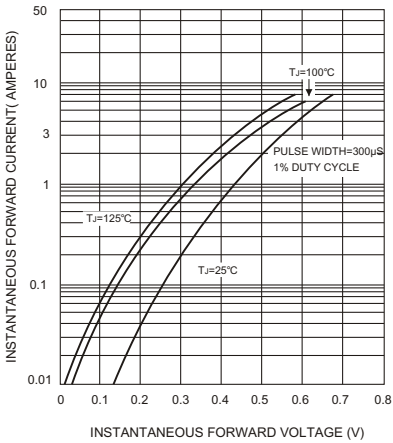

FIG.4-TYPICAL REVERSE CHARACTERISTICS

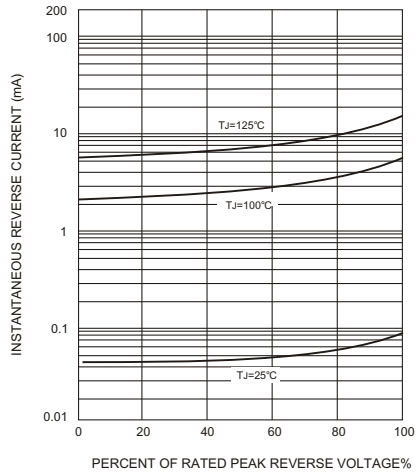

FIG.5-TYPICAL JUNCTION CAPACITANCE

