

FEATURES

- Plastic package has Underwriters Laboratory Flammability Classification 94V-0
- Low reverse leakage
- For surface mounted applications
- Built-in strain relief, ideal for automated placement
- High temperature soldering guaranteed:260°C/10 seconds at terminals
- Component in accordance to RoHS 2011/65/EU

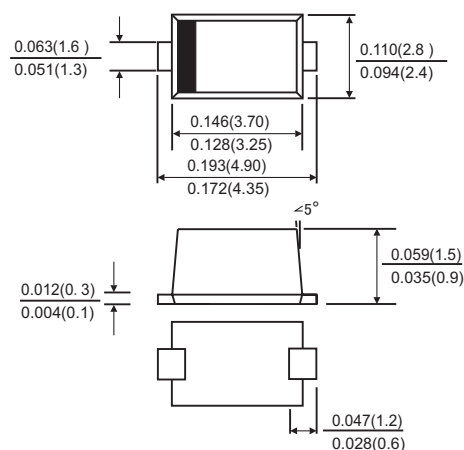

SMAF



Dimensions in inches and (millimeters)

MECHANICAL DATA

- Case: SMAF molded plastic over glass passivated chip
- Terminals: Solder plated, solderable per MIL-STD-750, Method 2026
- Polarity: Color band denotes cathode end

MAXIMUM RATINGS AND ELECTRICAL CHARACTERISTICS

(Ratings at 25°C ambient temperature unless otherwise specified ,Single phase ,half wave 60Hz ,resistive or inductive load. For capacitive load, derate by 20%.)

	Symbols	M1F	M2F	M3F	M4F	M5F	M6F	M7F	Units
Maximum Recurrent Peak Reverse Voltage	V_{RRM}	50	100	200	400	600	800	1000	Volts
Maximum RMS Voltage	V_{RMS}	35	70	140	280	420	560	700	Volts
Maximum DC Blocking Voltage	V_{DC}	50	100	200	400	600	800	1000	Volts
Maximum average Forward Rectified Current	$I_{(AV)}$	1.0							Amp
Peak Forward Surge Current (8.3ms half sine-wave superimposed on rated load (JEDEC method)	I_{FSM}	30.0							Amps
Maximum Instantaneous Forward Voltage at 1.0 A	V_F	1.1							Volts
Maximum Reverse current at rated DC Blocking Voltage	I_R	$T_A=25^\circ\text{C}$							μA
		$T_A=100^\circ\text{C}$							
Typical Thermal resistance (Note 2)	$R_{\theta JA}$	75							$^\circ\text{C}/\text{W}$
	$R_{\theta JL}$	27							
Typical Junction Capacitance(Note 1)	C_J	15							pF
Operating and Storage temperature Range	T_J, T_{STG}	-55 to+150							$^\circ\text{C}$

Note: 1.Measured at 1MHz and applied reverse voltage of 4.0V DC.

2.Thermal resistance from junction to ambient , P.C.B. Mounted with0.2×0.2" (0.5×0.5mm) copper pad areas

RATINGS AND CHARACTERISTIC CURVES M1F THRU M7F

FIG.1-FORWARD CURRENT DERATING CURVE

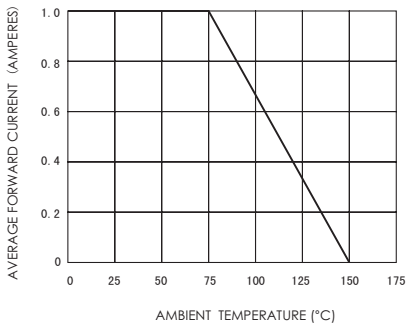

FIG.2-TYPICAL INSTANTANEOUS FORWARD CHARACTERISTICS

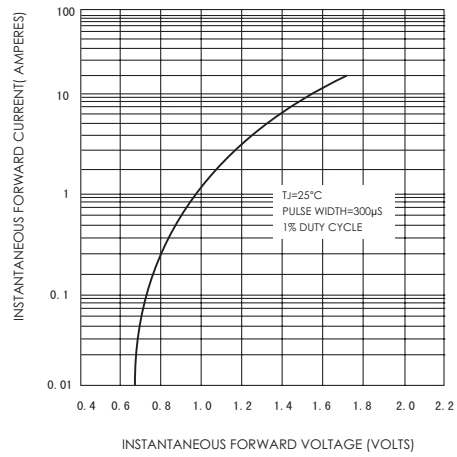

FIG.3-MAXIMUM NON-REPETITIVE PEAK FORWARD SURGE CURRENT

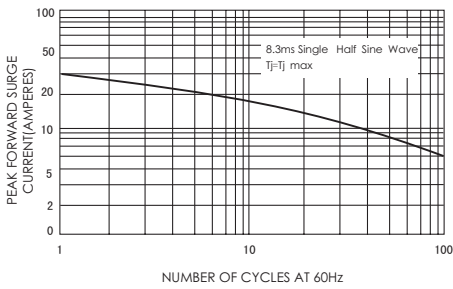

FIG.4-TYPICAL REVERSE CHARACTERISTICS

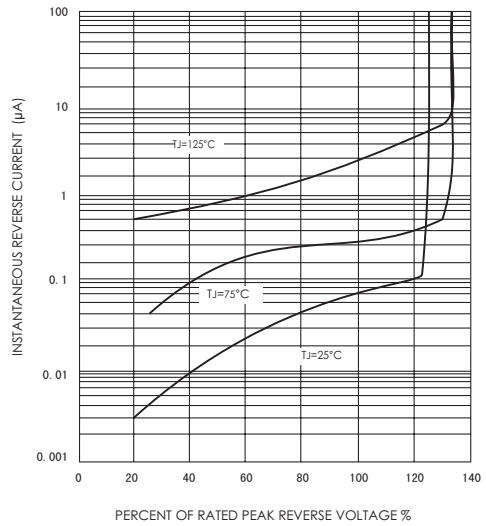

FIG.5-TYPICAL JUNCTION CAPACITANCE

