

Features

- High Reliability Capability
- Extremely low on-resistance RDS(on)
- Excellent gate charge x RDS(on) product(FOM)

Product Summary			
V _{DS}	R _{DS(on)} (mΩ) Typ	I _D (A)	Q _g (Typ)
40V	2.5 @ 10V 30A	109	23nc

Mechanical Data

- Case:DFN5×6 Package

DFN5×6
D030N04G

Application

- Charger
- DC/DC converter
- General purpose applications
- Ideal for high-frequency switching and synchronous rectification

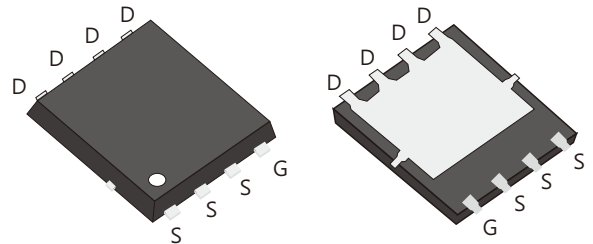

Ordering Information

Part No.	Package Type	Package	Quality(box)
D030N04G	DFN5×6	Tape & Reel	5000

Block Diagram

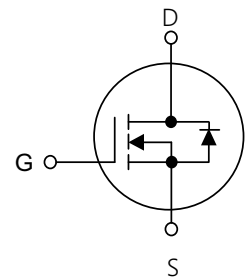

Table1 Absolute Maximum Ratings (T_c=25°C, unless otherwise specified)

Parameter	Symbol	Value	Unit
Drain-Source Voltage	V _{DS}	40	V
Gate-Source Voltage	V _{GS}	±20	V
Continuous Drain Current	I _D	T _c =25°C	109
		T _c =100°C	70
Pulsed Drain Current (Note 1)	I _{DM}	410	A
Single Pulse Avalanche Energy(Note 2)	E _{AS}	132	mJ
Power Dissipation T _c =25°C	P _D	63	W
Operating Junction and Storage Temperature	T _J /T _{STG}	-55~+150	°C

Table 2. Thermal Characteristics

Parameter	Symbol	Value	Unit
Thermal resistance Junction to Ambient	$R_{\theta JA}$	62	$^{\circ}\text{C}/\text{W}$
Thermal resistance Junction to Case	$R_{\theta JC}$	2.0	$^{\circ}\text{C}/\text{W}$

Table 3. Electrical Characteristics ($T_J=25^{\circ}\text{C}$, unless otherwise specified)

Parameter	Symbol	Test Conditions	Min	Typ	Max	Unit	
Off Characteristics							
Drain-Source Breakdown Voltage	BV_{DSS}	$V_{GS}=0V, I_D=250\mu\text{A}$	40	-	-	V	
Drain-Source Leakage Current	I_{DSS}	$V_{DS}=40V, V_{GS}=0V$	-	-	1	μA	
Gate- Source Leakage Current	Forward	I_{GSS}	$V_{GS}=20V, V_{DS}=0V$	-	-	100	nA
	Reverse	I_{GSS}	$V_{GS}=-20V, V_{DS}=0V$	-	-	-100	nA
On Characteristics(Note 3)							
Gate Threshold Voltage	$V_{GS(TH)}$	$V_{DS}=V_{GS}, I_D=250\mu\text{A}$	2.4	3.0	3.6	V	
Static Drain-Source On-State Resistance	$R_{DS(ON)}$	$V_{GS}=10V, I_D=30A$	-	2.5	3.0	m Ω	
Dynamic Characteristics(Note 4)							
Input Capacitance	C_{ISS}	$V_{DS}=20V, V_{GS}=0V, f=1\text{MHz}$	-	1453	-	pF	
Output Capacitance	C_{OSS}		-	999	-	pF	
Reverse Transfer Capacitance	C_{RSS}		-	45	-	pF	
Switching Characteristics (Note 4)							
Turn-On Delay Time	$t_d(\text{on})$	$V_{DS}=20V, I_D=30A, V_{GS}=10V, R_L=3\Omega,$	-	5	-	ns	
Turn-On Rise Time	t_r		-	7	-	ns	
Turn-Off Delay Time	$t_d(\text{off})$		-	35	-	ns	
Turn-Off Fall Time	t_f		-	21	-	ns	
Total Gate Charge	Q_G	$V_{DS}=20V, I_D=30A, V_{GS}=10V$	-	23	-	nC	
Gate-Source Charge	Q_{GS}		-	4	-	nC	
Gate-Drain Charge	Q_{GD}		-	7	-	nC	
Drain-Source Diode Characteristics and Maximum Ratings							
Drain-Source Diode Forward Voltage	V_{SD}	$V_{GS}=0V, I_S=30A$	-	-	1.2	V	
Maximum Continuous Drain-Source Diode Forward Current	I_S		-	-	109	A	
Reverse Recovery Time	t_{rr}	$V_{GS}=0V, I_F=30A, dI_F/dt=100A/\mu\text{s}$	-	29	-	ns	
Reverse Recovery Charge	Q_{RR}		-	13	-	nC	

Notes : 1 Repetitive Rating:Pulse width limited by maximum junction temperature

2 $L=0.5\text{mH}, R_G=25\Omega, \text{Starting } T_J=25^{\circ}\text{C}$

3 Pulse Test: Pulse width $\leq 300\mu\text{s}$, Duty cycle $\leq 2\%$

4 Guaranteed by design, not subject to production

Typical Characteristics Diagrams

Figure 1. Output Characteristics

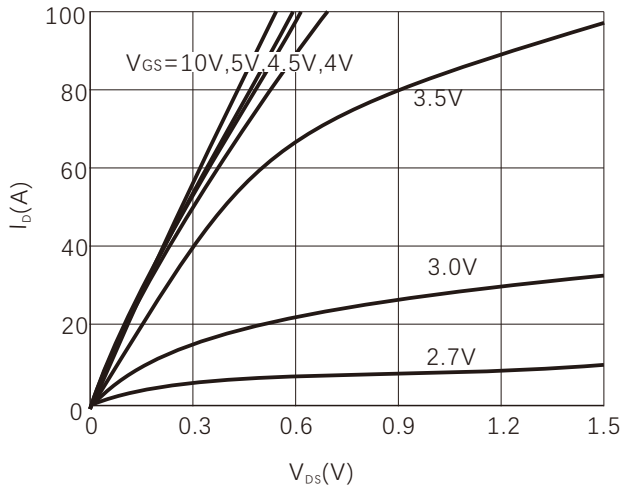

Figure 2. Normalized $R_{DS(ON)}$ vs Temperature

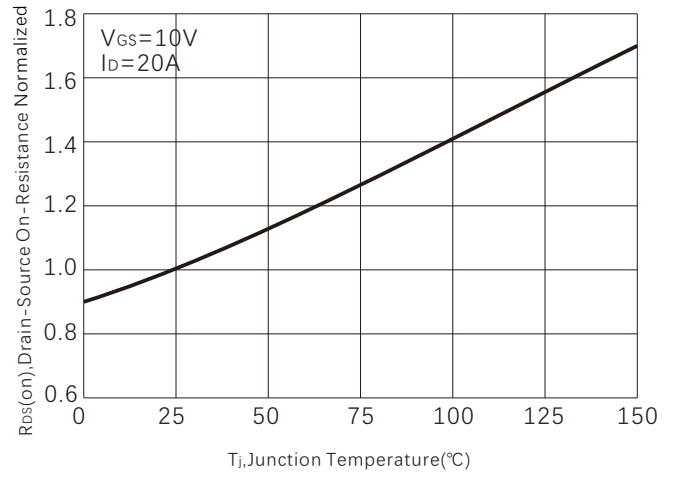

Figure 3. On-Resistance vs. Drain Current

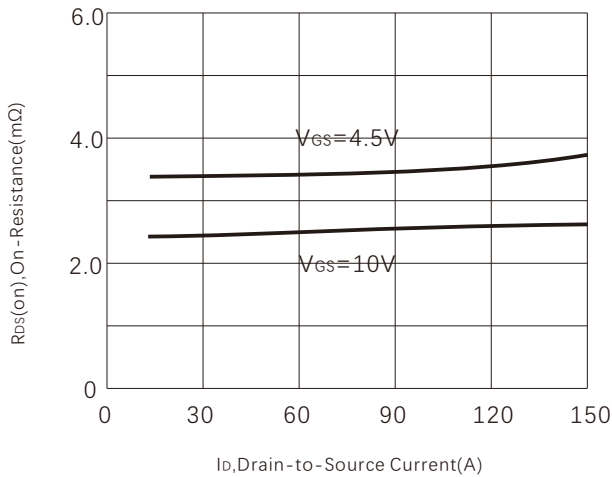

Figure 4. Capacitance

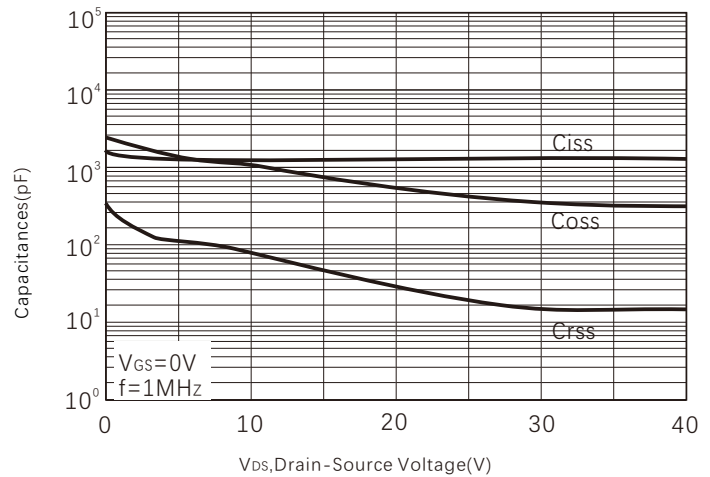

Figure 5. Power Dissipation

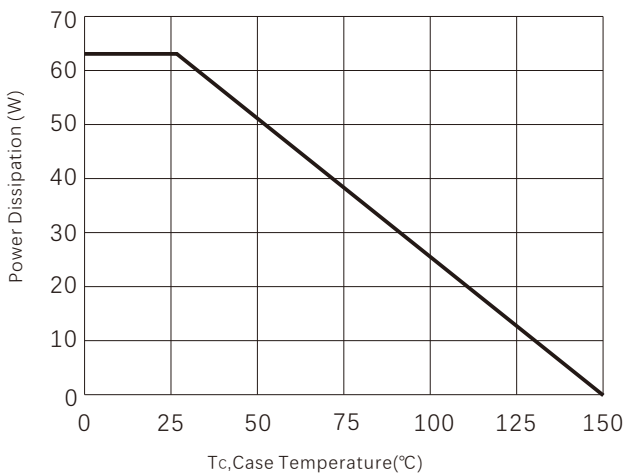

Figure 6. Source-Drain Diode Forward Voltage

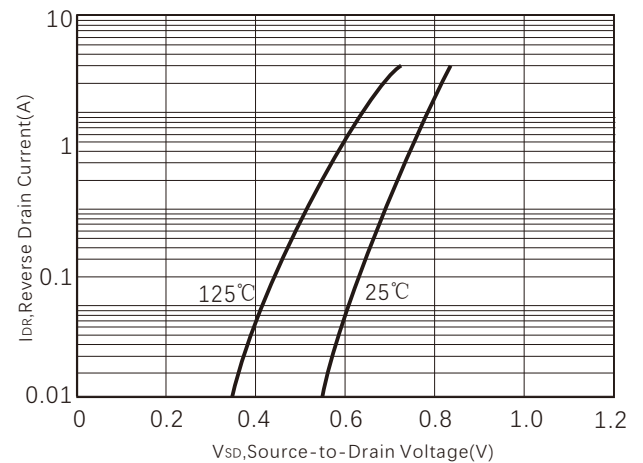

Figure 7. Maximum Drain Current vs Temperature

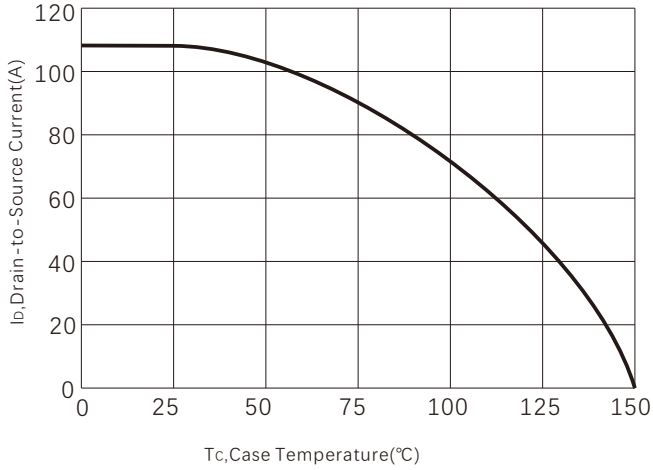

Figure 8. Transfer Characteristics

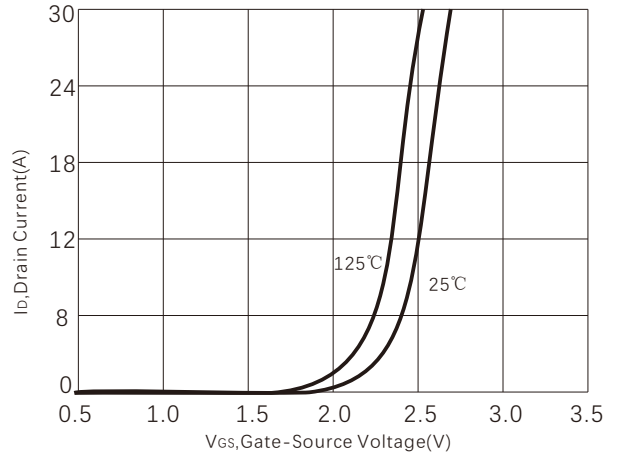

Figure 9. Safe operating area

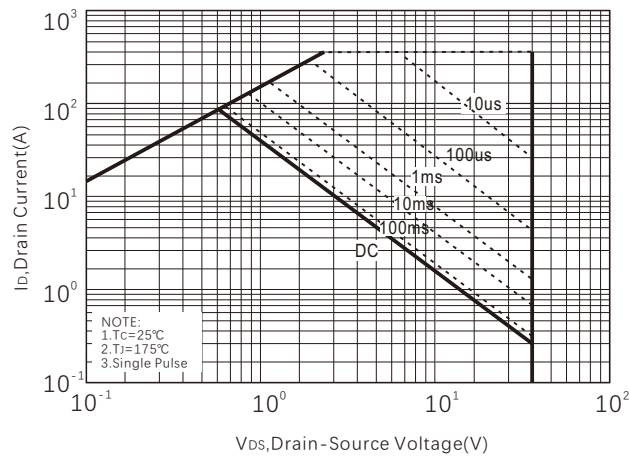
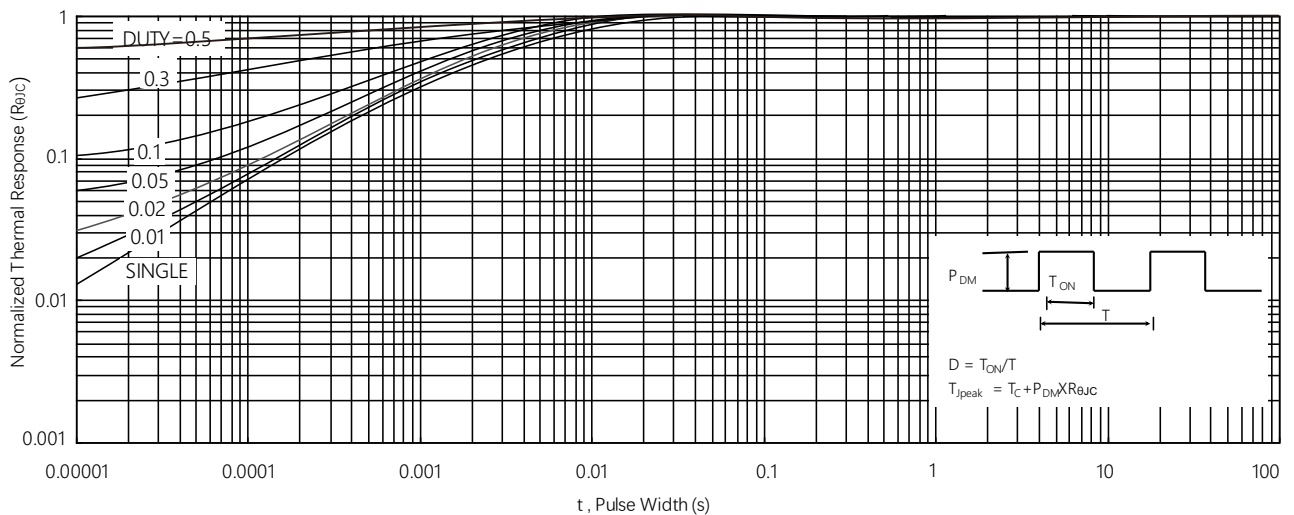
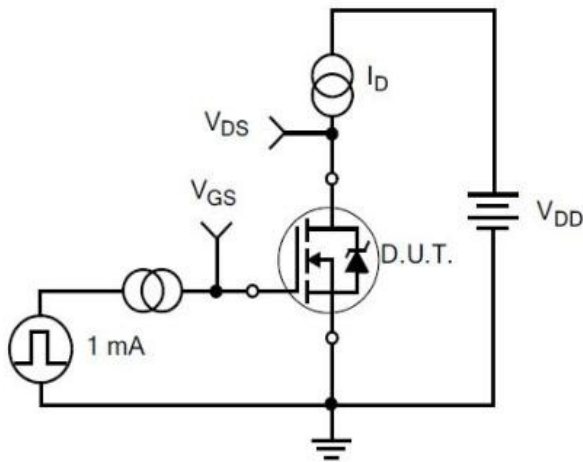

Figure 10. Normalized Maximum Transient Thermal Impedance



Typical Test Circuit



1) Gate Charge Test Circuit

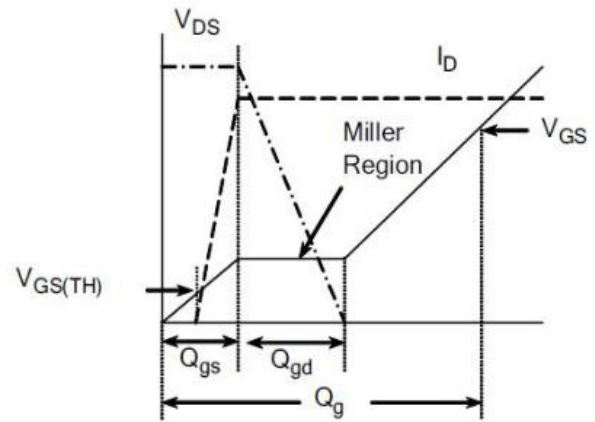

2) Gate Charge Waveform

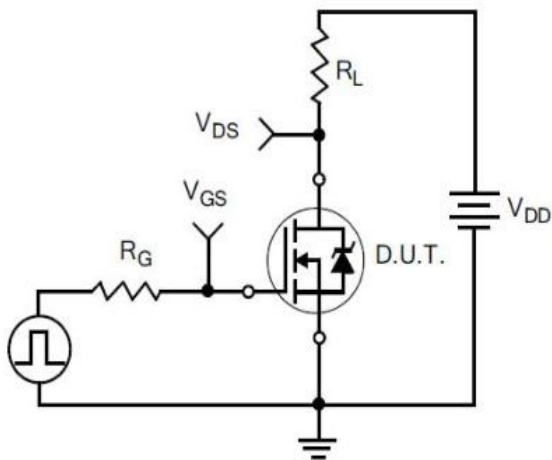

3) Resistive Switching Test Circuit

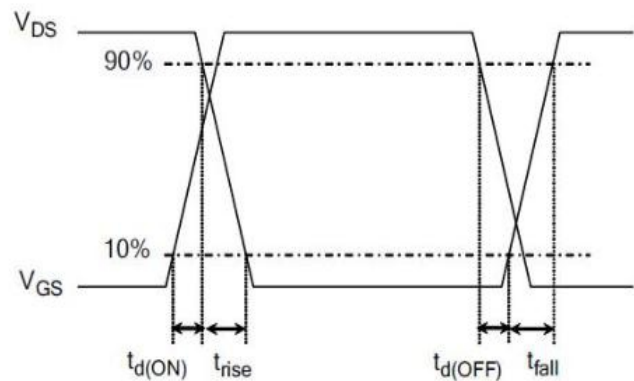

4) Resistive Switching Waveforms

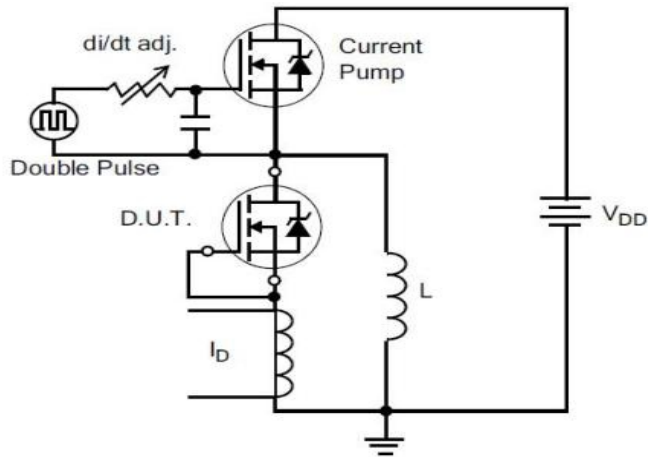

5) Diode Reverse Recovery Test Circuit

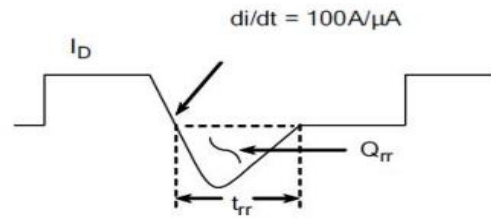

6) Diode Reverse Recovery Waveform

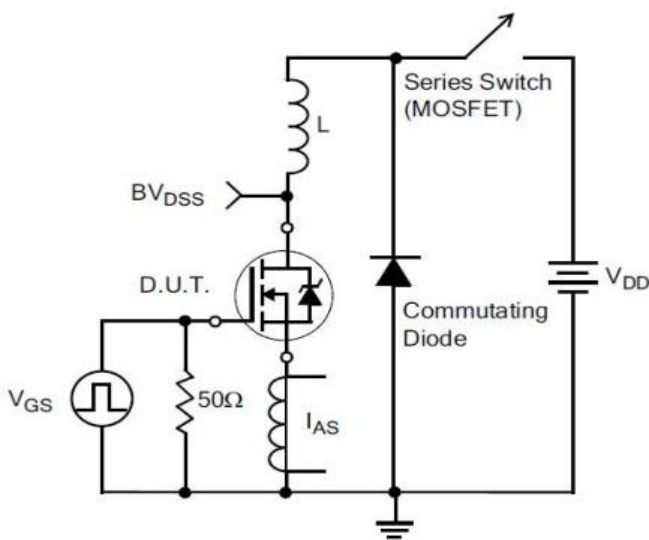

7) . Unclamped Inductive Switching Test Circuit

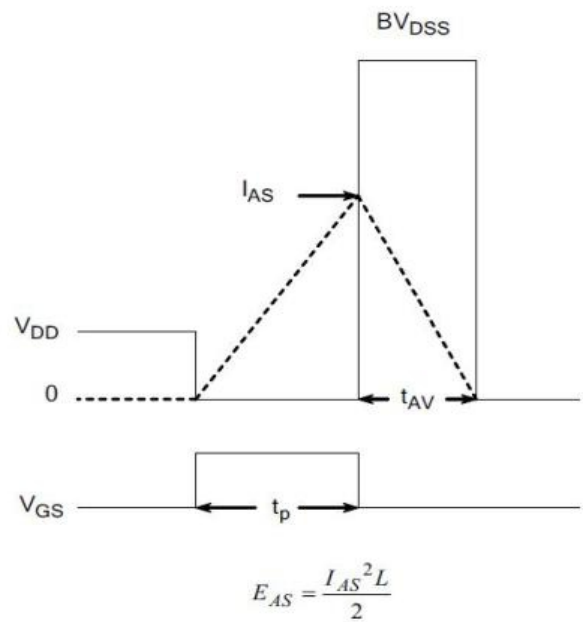

8) Unclamped Inductive Switching Waveforms

Product Names Rules

X X X X N E X X X

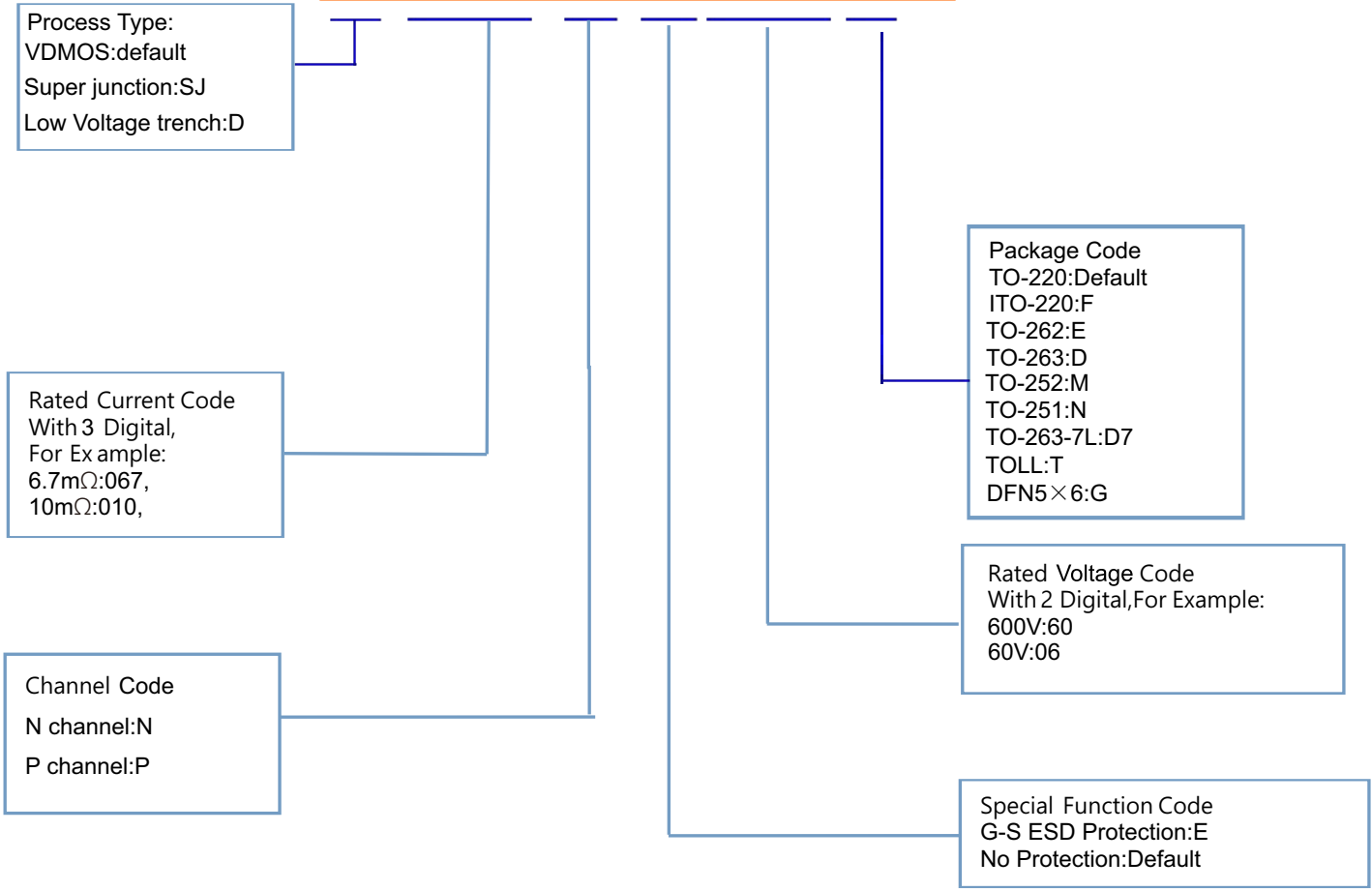

Dimensions

DFN5×6 PACKAGE OUTLINE DIMENSIONS

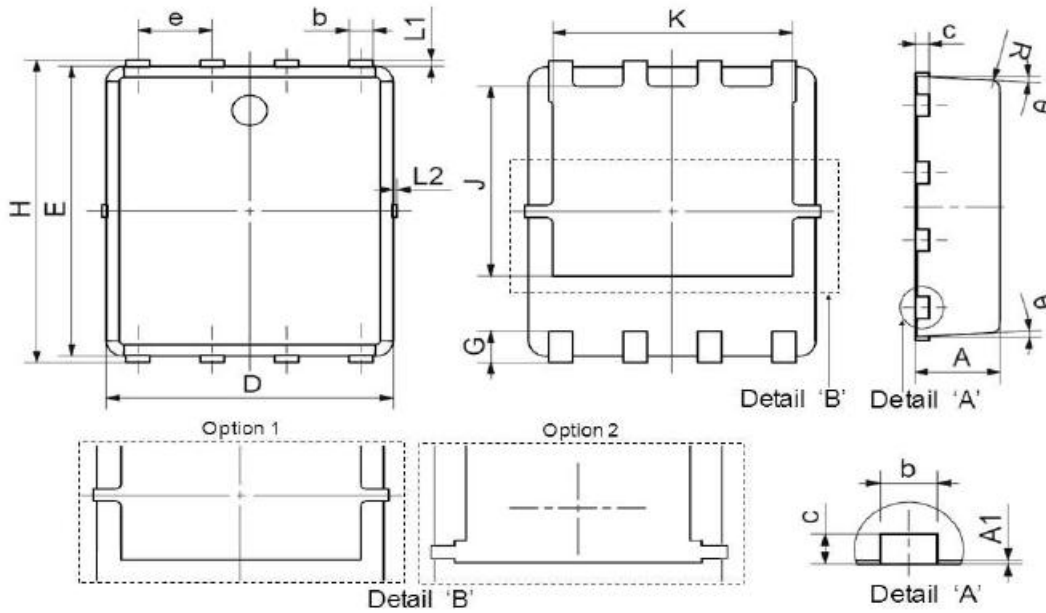

Symbol	Dimensions In Millimeters		Dimensions In Inches	
	Min.	Max.	Min.	Max.
A	0.80	1.20	0.031	0.047
A1	0.00	0.05	0.000	0.002
b	0.30	0.51	0.012	0.020
c	0.15	0.35	0.006	0.014
D	4.80	5.40	0.189	0.213
e	1.27 BSC		0.050 BSC	
E	5.66	6.06	0.223	0.239
G	0.30	0.71	0.012	0.028
H	5.90	6.35	0.232	0.250
J	3.32	3.92	0.131	0.154
K	3.61	4.25	0.142	0.167
L1	0.05	0.25	0.002	0.010
L2	0.00	0.15	0.000	0.006
R	0.25 REF		0.010 REF	
θ	0°	12°	0°	12°

Friendship Reminder

- JiNan JingHeng (hereinafter referred to as JH) reserves the right to make changes to this document and its products and specifications at anytime without notice.
- Customers should obtain and confirm the latest product information and specifications before final design, purchase or use.
- JH makes no warranty, representation or guarantee regarding the suitability of its products for any particular purpose, nor does JH assume any liability for application assistance or customer product design.
- JH does not warrant or accept any liability with products which are purchased or used for any unintended or unauthorized application.
- No license is granted by implication or otherwise under any intellectual property rights of JH.
- JH's products are not authorized for use as critical components in life support devices or systems without express written approval of JH.