

FEATURES

- New revolutionary high voltage technology
- Ultra Low gate charge
- Periodic avalanche rated
- Extreme dv/dt rated
- $R_{DS(ON)} < 75m\Omega @ V_{GS}=10V$
- RoHS compliant

PRODUCT SUMMARY

$V_{DS}(V)$	$R_{DS(on)}(m\Omega)_{Typ}$	$I_D(A)$
600	65@ $V_{GS}=10V$	47

TO-247

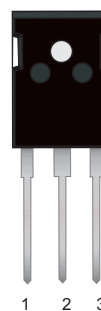

MECHANICAL DATA

- TO-247 package

Ordering Information

Part No.	Package Type	Package	Quality(box)
SJ47N60PR	TO-247	Tube	360

Pin Definition:

1. Gate
2. Drain
3. Source

Block Diagram

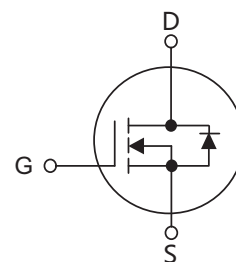

Table1 Absolute Maximum Ratings ($T_C=25^\circ C$, unless otherwise specified)

Parameter	Symbol	Value	Unit
Drain-Source Voltage	V_{DS}	600	V
Gate-Source Voltage	V_{GS}	± 30	V
Continuous Drain Current	I_D	$T_C=25^\circ C$	47
		$T_C=100^\circ C$	29
Pulsed Drain Current (Note 1)	I_{DM}	140	A
Single Pulse Avalanche Energy(Note 2)	E_{AS}	1160	mJ
Avalanche Current(Note 1)	I_{AR}	10	A
Repetitive Avalanche Energy(Note 1)	E_{AR}	1.72	mJ
Peak Diode Recovery dv/dt(Note 3)	dv/dt	15	V/ns
Drain Source voltage slope($V_{ds}=480V$)	d V_{ds}/dt	50	V/ns
Power Dissipation $T_C=25^\circ C$	P_D	391	W
Operating Junction and Storage Temperature	T_J/T_{STG}	-55 ~ +150	$^\circ C$
Maximum Temperature for soldering	T_L	300	$^\circ C$

SJ47N60PR

Table 2. Thermal Characteristics

Parameter	Symbol	Value	Unit
Thermal resistance Junction to Ambient	$R_{\theta JA}$	62	$^{\circ}C/W$
Thermal resistance Junction to Case	$R_{\theta JC}$	0.32	$^{\circ}C/W$

Table 3. Electrical Characteristics ($T_J=25^{\circ}C$, unless otherwise specified)

Parameter	Symbol	Test Conditions	Min	Typ	Max	Unit
Off Characteristics						
Drain-Source Breakdown Voltage	BV_{DSS}	$V_{GS}=0V, I_D=250\mu A$	600	--	--	V
Drain-Source Leakage Current	I_{DSS}	$V_{DS}=600V, V_{GS}=0V$	--	--	6	μA
Gate- Source Leakage Current	Forward	$V_{GS}=30V, V_{DS}=0V$	--	--	100	nA
	Reverse	$V_{GS}=-30V, V_{DS}=0V$	--	--	-100	nA
On Characteristics(Note 4)						
Gate Threshold Voltage	$V_{GS(TH)}$	$V_{DS}=V_{GS}, I_D=250\mu A$	2.5	--	4.5	V
Static Drain-Source On-State Resistance	$R_{DS(ON)}$	$V_{GS}=10V, I_D=23A$	--	65	75	m Ω
Dynamic Characteristics(Note 5)						
Input Capacitance	C_{ISS}	$V_{DS}=25V, V_{GS}=0V, f=1MHz$	--	3100	--	pF
Output Capacitance	C_{OSS}		--	148	--	pF
Reverse Transfer Capacitance	C_{RSS}		--	5	--	pF
Switching Characteristics (Note 5)						
Turn-On Delay Time	$t_d(on)$	$V_{DD}=480V, I_D=23A,$ $R_G=20\Omega$	--	19	--	ns
Turn-On Rise Time	t_R		--	10	--	ns
Turn-Off Delay Time	$t_d(off)$		--	87	--	ns
Turn-Off Fall Time	t_f		--	5	--	ns
Total Gate Charge	Q_G	$V_{DS}=480V, I_D=23A,$ $V_{GS}=10V$	--	190	--	nC
Gate-Source Charge	Q_{GS}		--	30	--	nC
Gate-Drain Charge	Q_{GD}		--	95	--	nC
Drain-Source Diode Characteristics and Maximum Ratings						
Drain-Source Diode Forward Voltage	V_{SD}	$V_{GS}=0V, I_S=23A$	--	0.9	1.5	V
Maximum Continuous Drain-Source Diode Forward Current	I_S		--	--	47	A
Reverse Recovery Time	t_{rr}	$V_{GS}=0V, I_S=23A$	--	210	--	ns
Reverse Recovery Charge	Q_{RR}	$di/dt=100A/\mu s$ (Note 1)	--	19	--	μC

Notes : 1 Repetitive Rating: Pulse width limited by maximum junction temperature

2 Pulse width t_p limited by $T_{j,max}$

3 Identical low side and high side switch with identical R_G ; $V_{peak} < V(BR)_{DSS}$; $T_j < T_{j,max}$

4 Pulse Test: Pulse width $\leq 300\mu s$, Duty cycle $\leq 2\%$

5 Guaranteed by design, not subject to production

SJ47N60PR

Typical characteristics Diagrams

Power dissipation

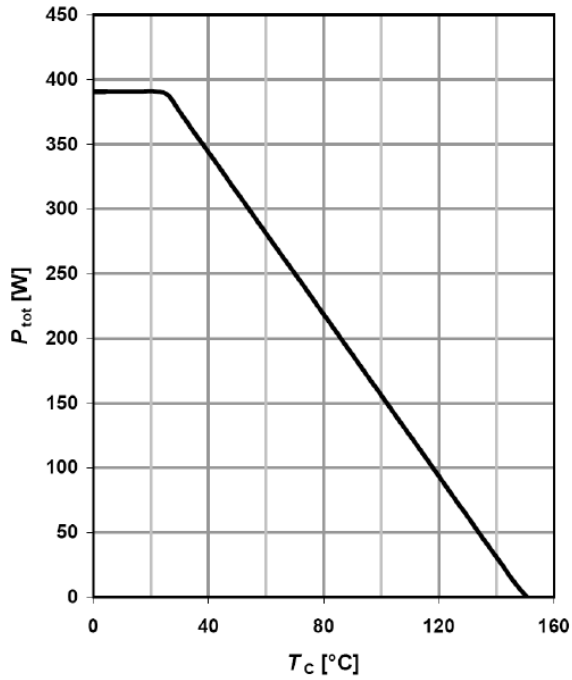

$$P_{tot} = f(T_c)$$

Max. transient thermal impedance

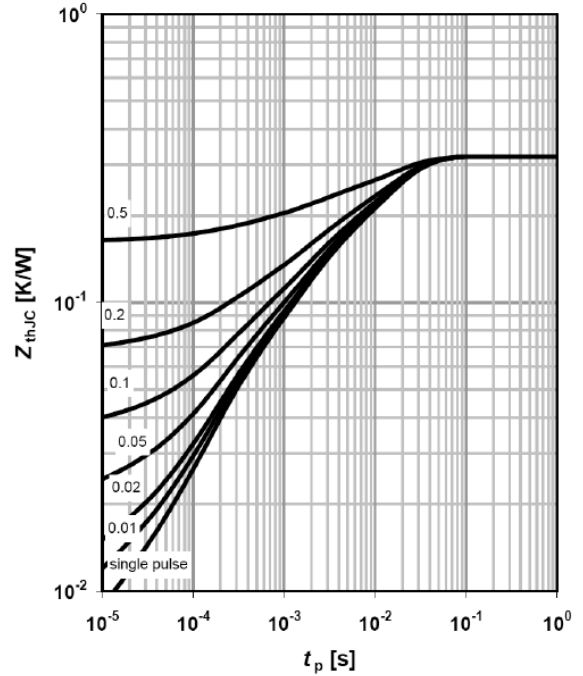

$$Z_{th(jc)} = f(t_p); \text{ parameter: } D = t_p / T$$

Safe operating area $T_c = 25^\circ\text{C}$

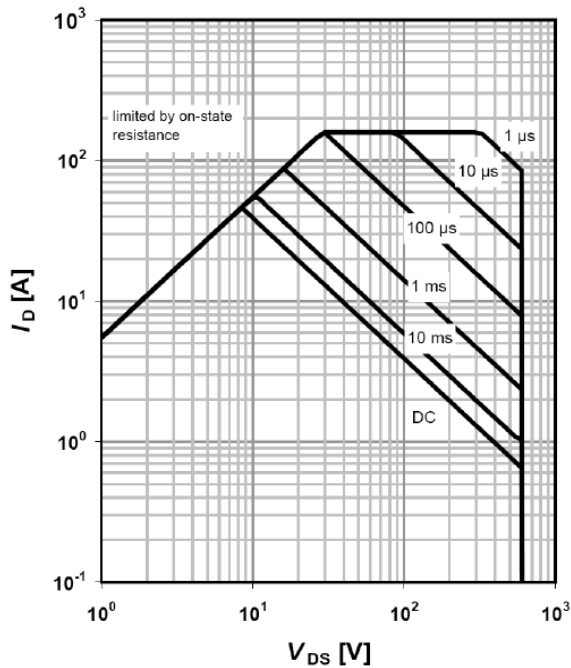

$$I_D = f(V_{DS}); T_c = 25^\circ\text{C}; V_{GS} > 7\text{V}; D = 0; \text{ parameter } t_p$$

Safe operating area $T_c = 80^\circ\text{C}$

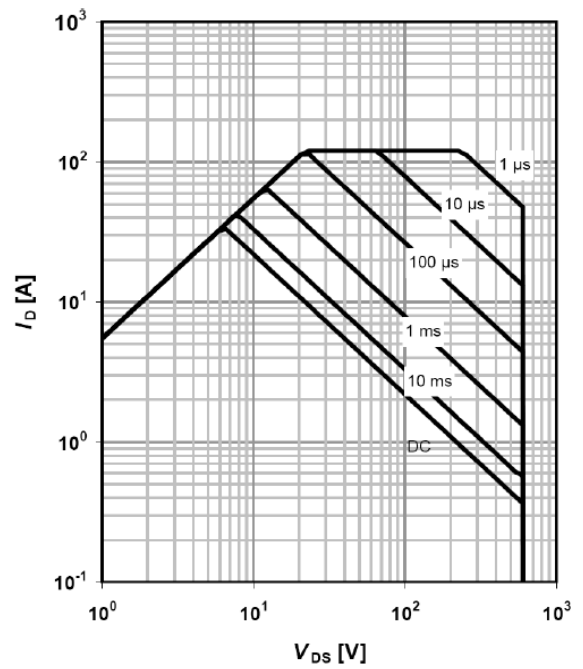

$$I_D = f(V_{DS}); T_c = 80^\circ\text{C}; V_{GS} > 7\text{V}; D = 0; \text{ parameter } t_p$$

SJ47N60PR

Typical characteristics Diagrams

Typ. output characteristics $T_j=25\text{ }^\circ\text{C}$

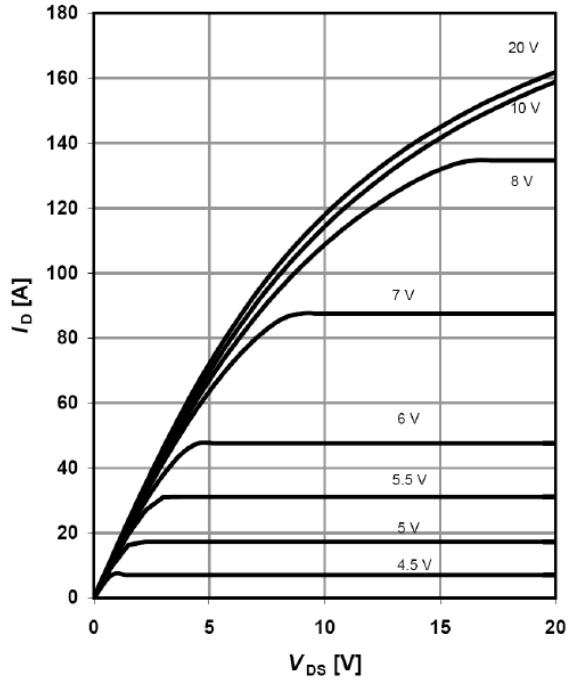

$I_D=f(V_{DS}); T_j=25\text{ }^\circ\text{C};$ parameter: V_{GS}

Typ. output characteristics $T_j=125\text{ }^\circ\text{C}$

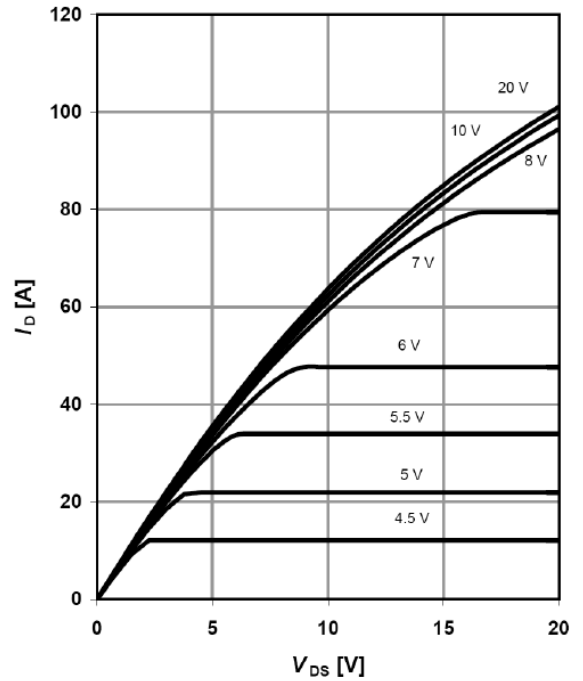

$I_D=f(V_{DS}); T_j=125\text{ }^\circ\text{C};$ parameter: V_{GS}

Typ. drain-source on-state resistance

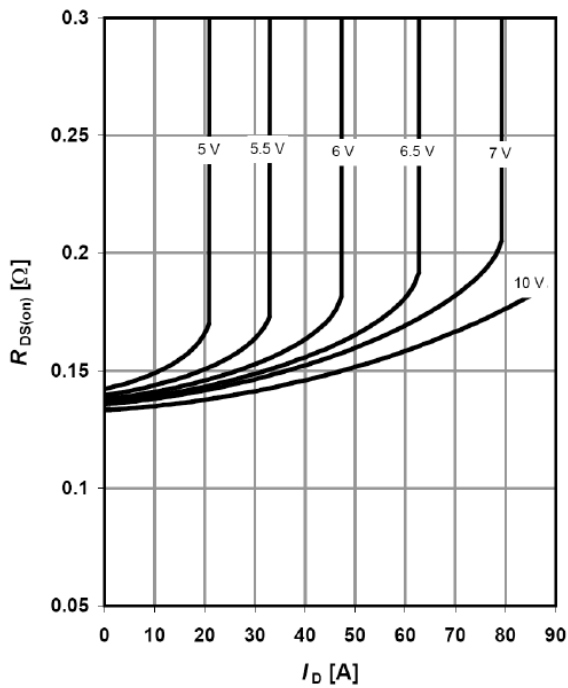

$R_{DS(on)}=f(I_D); T_j=125\text{ }^\circ\text{C};$ parameter: V_{GS}

Drain-source on-state resistance

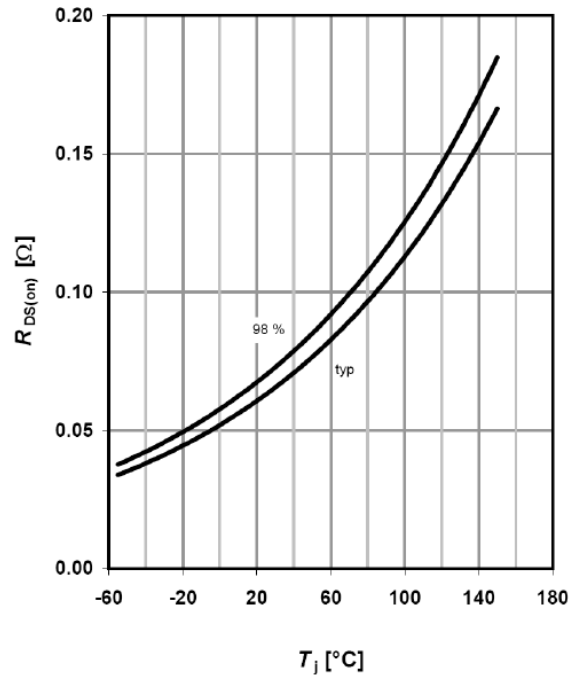

$R_{DS(on)}=f(T_j); I_D=17.6\text{ A}; V_{GS}=10\text{ V}$

SJ47N60PR

Typical characteristics Diagrams

Typ. transfer characteristics

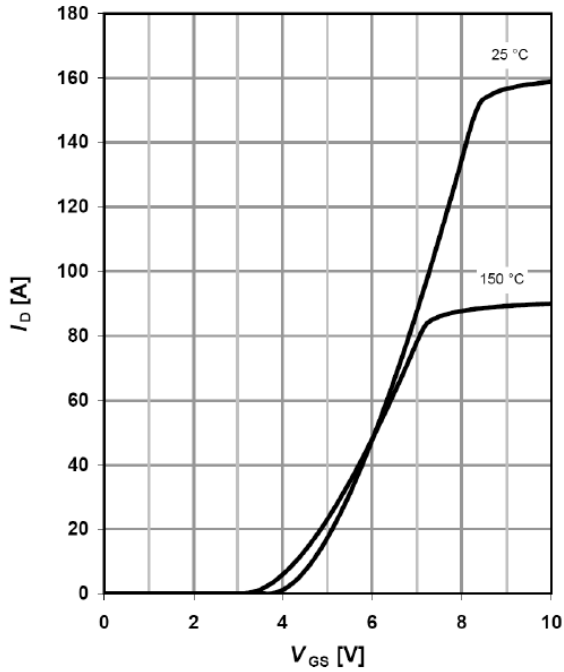

$I_D = f(V_{GS}); V_{DS} = 20V$

Typ. gate charge

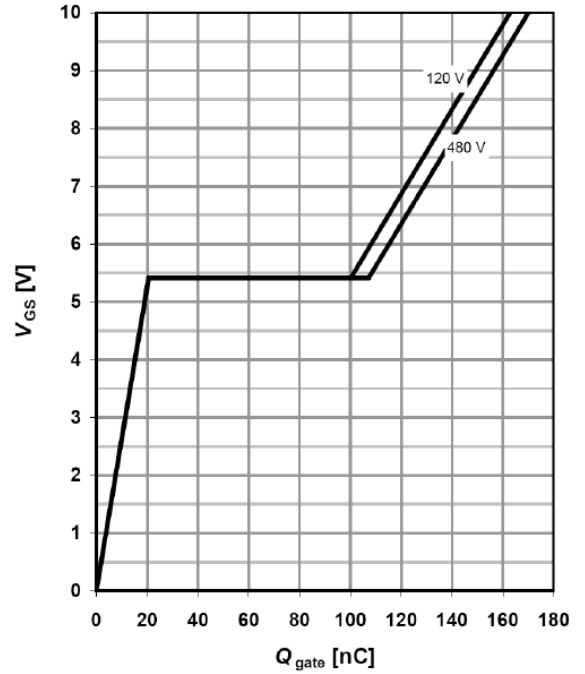

$V_{GS} = f(Q_{gate}), I_D = 26.3 A$ pulsed

Avalanche energy

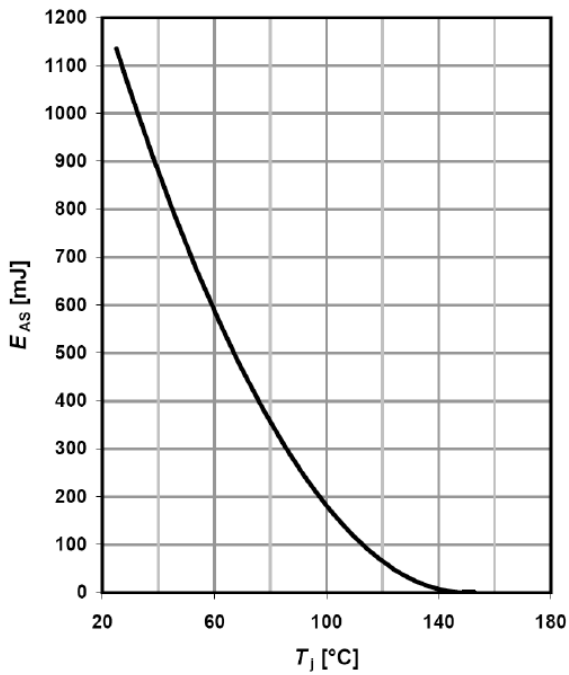

$E_{AS} = f(T_j); I_D = 9.3 A; V_{DD} = 50 V$

Drain-source breakdown voltage

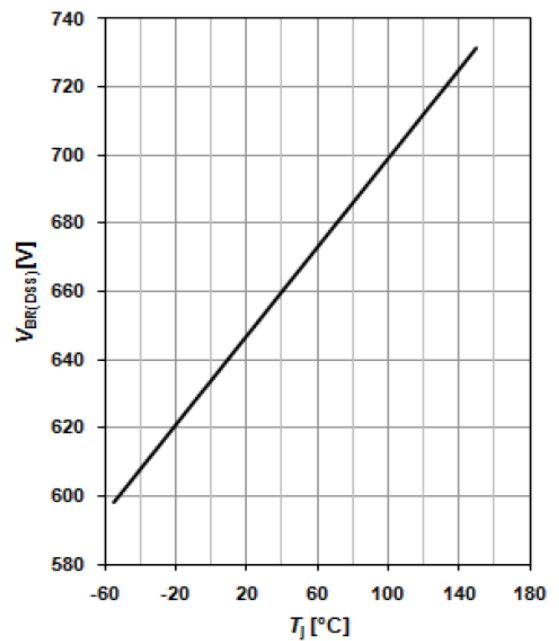

$V_{BR(DSS)} = f(T_j); I_D = 1.0 mA$

SJ47N60PR

Typical characteristics Diagrams

Typ. capacitances

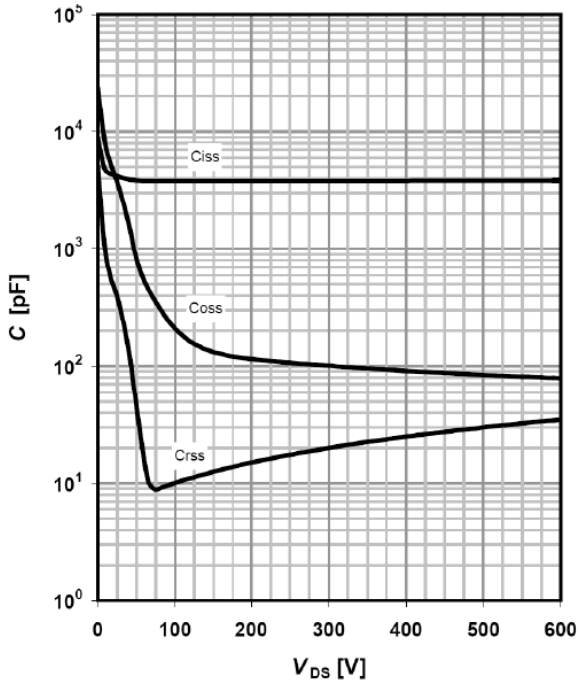

$C=f(V_{DS}); V_{GS}=0\text{ V}; f=1\text{ MHz}$

Typ. C_{oss} stored energy

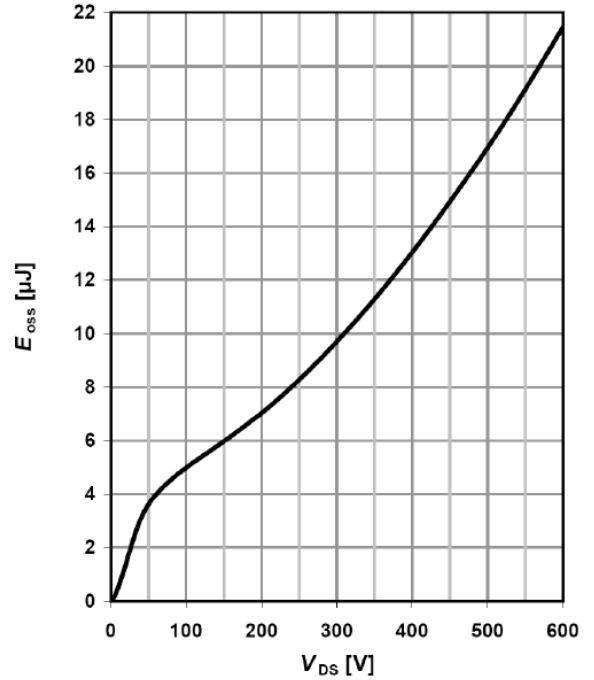

$E_{Oss}=f(V_{DS})$

Forward characteristics of reverse diode

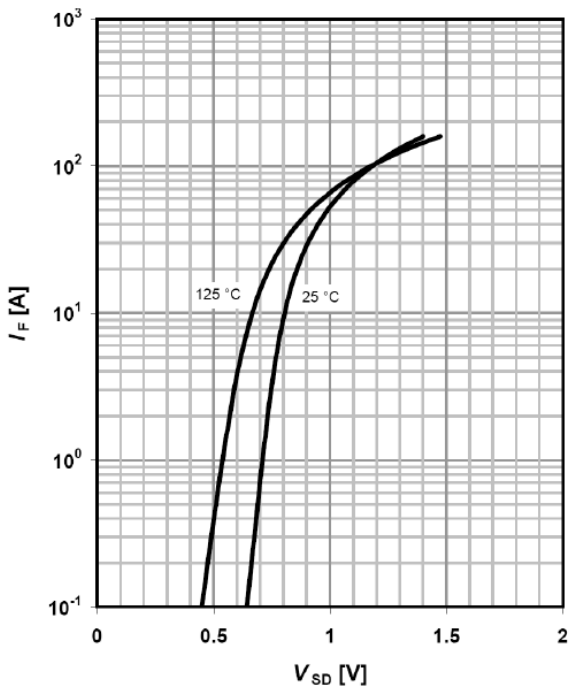

$I_F=f(V_{SD}); \text{parameter: } T_j$

SJ47N60PR

Switching times test circuit and waveform for inductive load

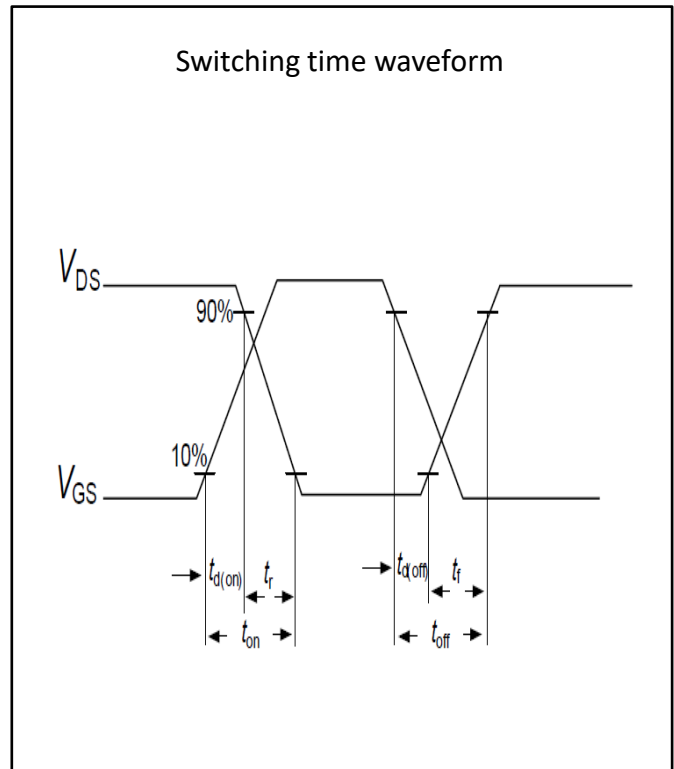
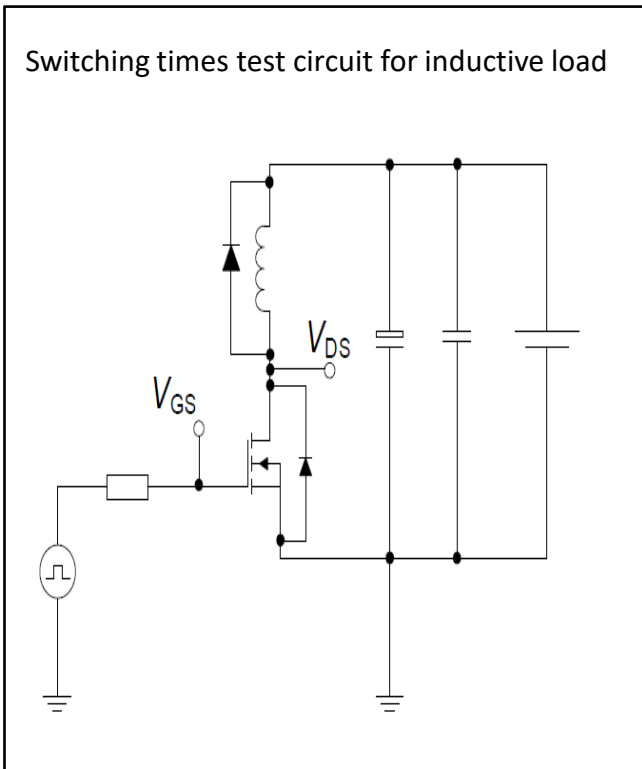

Unclamped inductive load test circuit and waveform

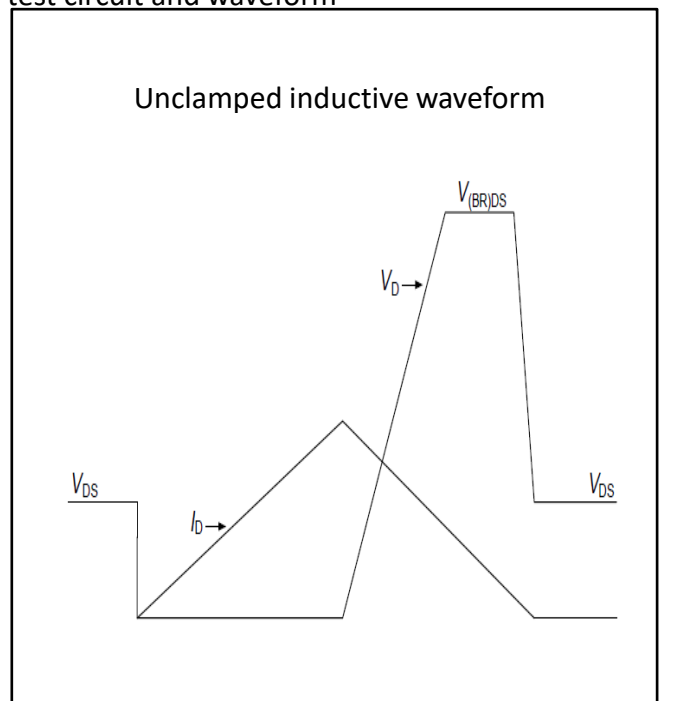
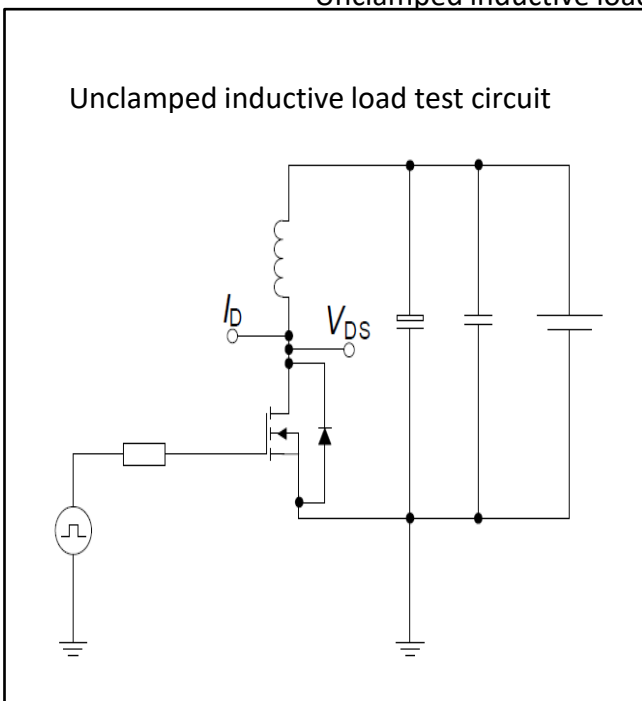

SJ47N60PR

Test circuit and waveform for diode characteristics

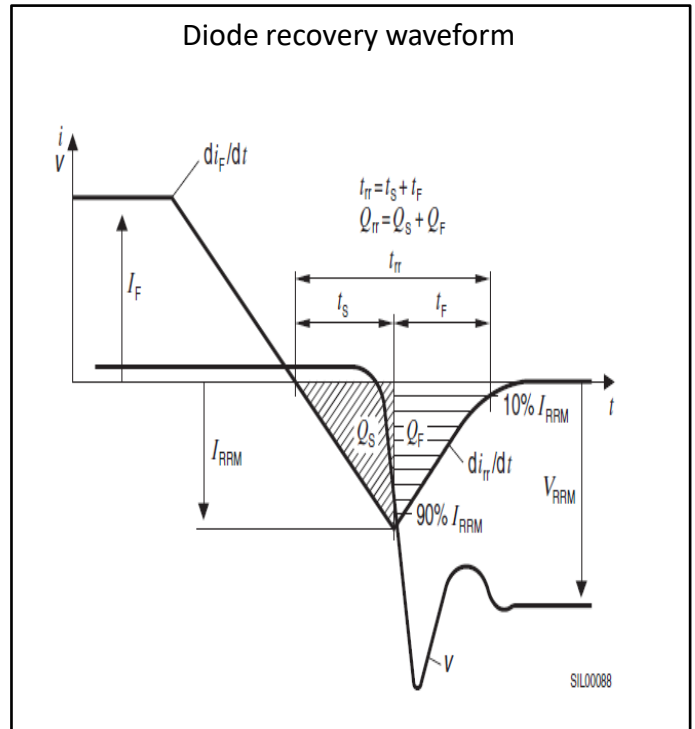
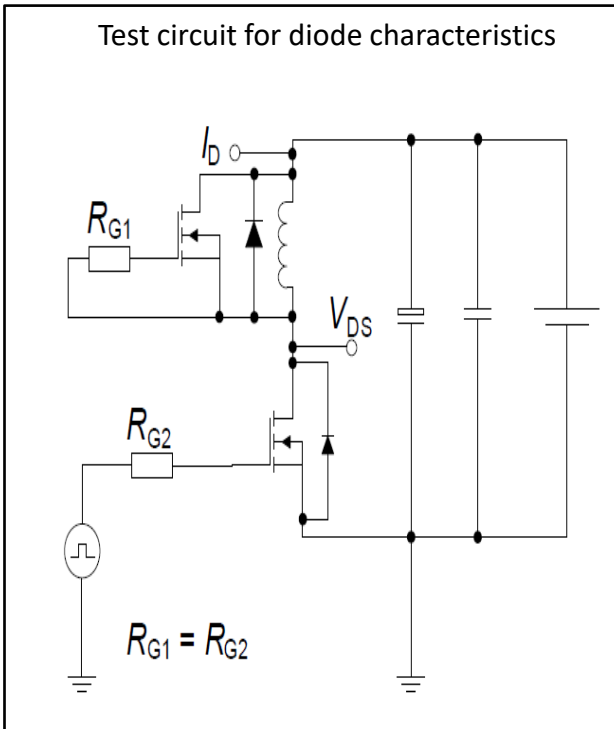

SJ47N60PR

Product Names Rules

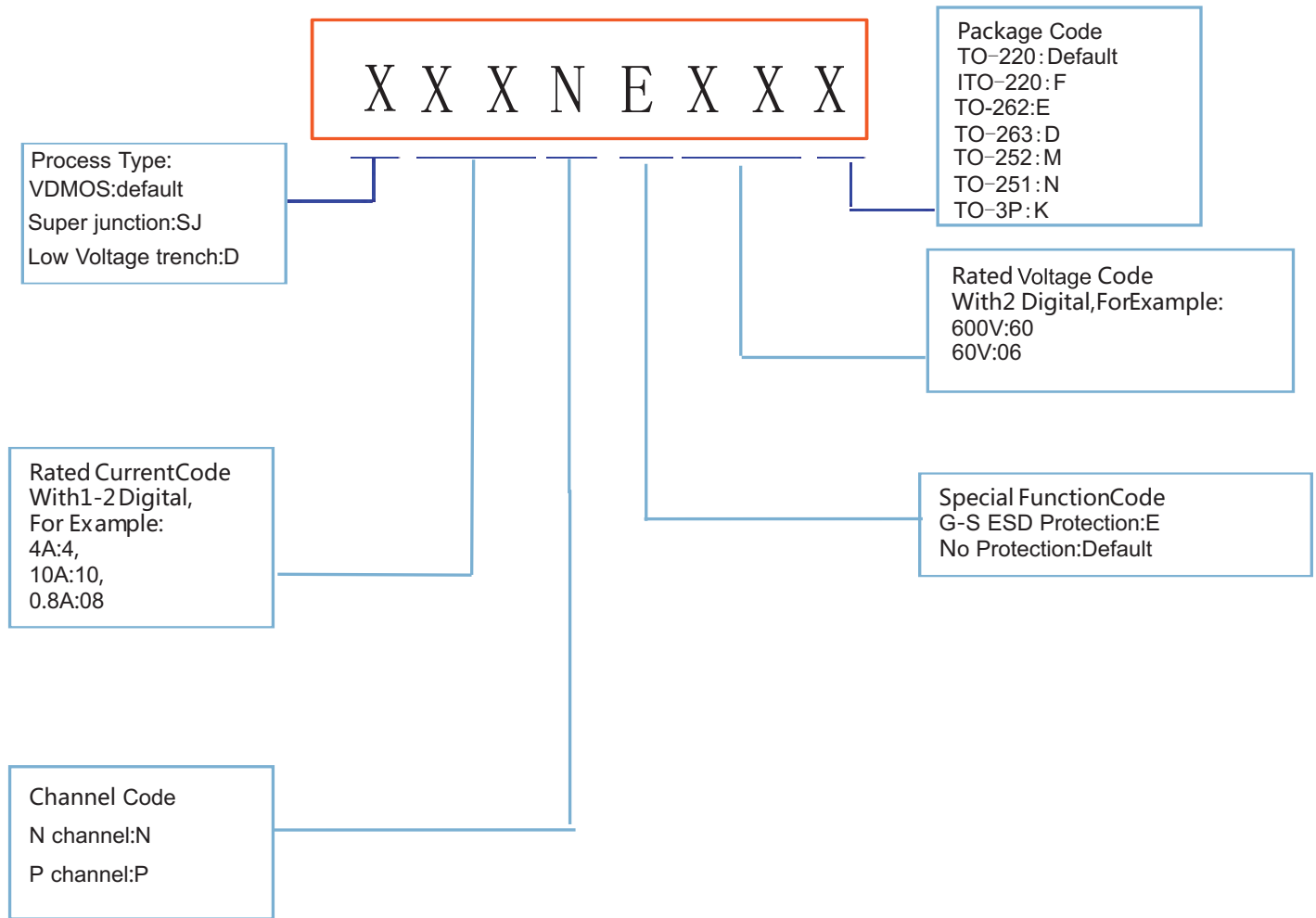

SJ47N60PR

TO-247 PACKAGE OUTLINE DIMENSIONS

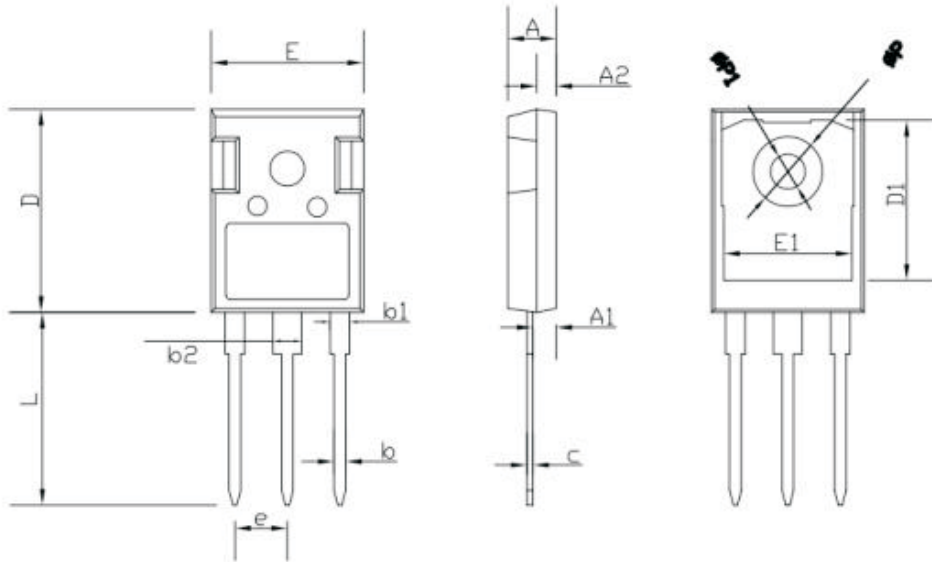

Symbol	Dimensions In Millimeters		Dimensions In Inches	
	min.	max.	min.	max.
A	4.90	5.10	0.193	0.201
A1	2.31	2.51	0.091	0.099
A2	1.90	2.10	0.075	0.083
b	1.16	1.26	0.046	0.050
b1	1.96	2.06	0.0772	0.0812
b2	2.96	3.06	0.117	0.121
c	0.59	0.66	0.0232	0.0260
D	20.90	21.10	0.8235	0.8313
D1	16.25	16.85	0.6403	0.6639
E	15.70	15.90	0.6186	0.6265
E1	13.10	13.50	0.5161	0.5319
e	5.44		0.2143	
L	19.80	20.10	0.7801	0.7919
ΦP	3.50	3.70	0.1379	0.1458
ΦP1	0	7.30	0	0.2876

Friendship Reminder

■ JiNan JingHeng (hereinafter referred to as JH) reserves the right to make changes to this document and its products and specifications at anytime without notice.

■ Customers should obtain and confirm the latest product information and specifications before final design, purchase or use.

■ JH makes no warranty, representation or guarantee regarding the suitability of its products for any particular purpose, nor does JH assume any liability for application assistance or customer product design.

■ JH does not warrant or accept any liability with products which are purchased or used for any unintended or unauthorized application.

■ No license is granted by implication or otherwise under any intellectual property rights of JH.

■ JH's products are not authorized for use as critical components in life support devices or systems without express written approval of JH.