

# MUR1020CT THRU MUR1060CT

GLASS PASSIVATED SUPER FAST RECTIFIER

Reverse Voltage - 200 -600 Volts

Forward Current - 10.0Ampers

## FEATURES

- Plastic package has Underwriters Laboratory Flammability Classification 94V-0
- Fast switching for high efficiency
- Low forward voltage drop
- Single rectifier construction
- High surge capability
- For use in low voltage ,high frequency inverters, free wheeling ,and polarity protection applications
- High temperature soldering guaranteed:260°C/10 seconds, 0.25"(6.35mm)from case
- Component in accordance to RoHS 2011/65/EU



## TO-220AB

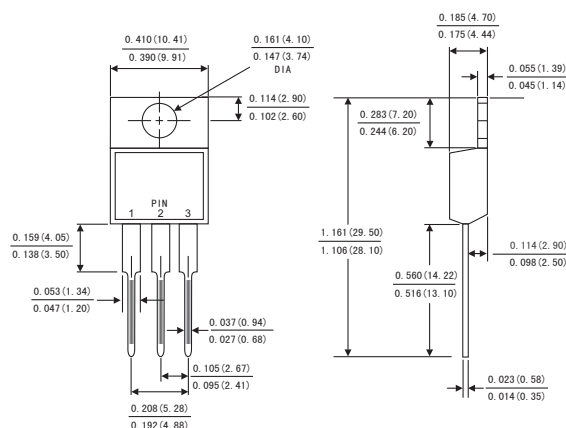

## MECHANICAL DATA

- Case: JEDEC TO-220AB molded plastic body
- Terminals: Lead solderable per MIL-STD-750,method 2026
- Polarity: As marked
- Mounting Position: Any

Dimensions in inches and (millimeters)

## MAXIMUM RATINGS AND ELECTRICAL CHARACTERISTICS

(Ratings at 25°C ambient temperature unless otherwise specified ,Single phase ,half wave ,resistive or inductive load. For capacitive load,derate by 20%.)

	Symbols	MUR 1020CT	MUR 1040CT	MUR 1060CT	Units
Maximum repetitive peak reverse voltage	$V_{RRM}$	200	400	600	Volts
Maximum RMS voltage	$V_{RMS}$	140	280	420	Volts
Maximum DC blocking voltage	$V_{DC}$	200	400	600	Volts
Maximum average forward rectified current(see Fig.1)	Per leg	5.0			Amps
	Total device	10.0			
Peak forward surge current 8.3ms single half sine-wave superimposed on rated load (JEDEC method)	$I_{FSM}$	120.0			Amps
Maximum instantaneous forward voltage at 5.0 A per leg(Note 1)	$V_F$	0.975	1.3	1.7	Volts
Maximum instantaneous reverse current at rated DC blocking voltage(Note 1)	$T_a=25^{\circ}C$	5			$\mu A$
	$T_a=125^{\circ}C$	50			
Maximum Reverse Recovery Time (Note 2)	$T_{rr}$	35			ns
Typical thermal resistance (Note 3)	$R_{\theta JC}$	2.5			$^{\circ}C/W$
Operating junction temperature range	$T_J$	-55 to+150			$^{\circ}C$
Storage temperature range	$T_{STG}$	-55 to+150			$^{\circ}C$

- Notes:**
1. Pulse test: 300 $\mu s$  pulse width,1% duty cycle
  2. Reverse recovery test conditions  $I_F=0.5A,I_R=1.0A,I_{rr}=0.5A$
  3. Thermal resistance from junction to case

# RATINGS AND CHARACTERISTIC CURVES MUR1020CT THRU MUR1060CT

FIG.1-FORWARD CURRENT DERATING CURVE

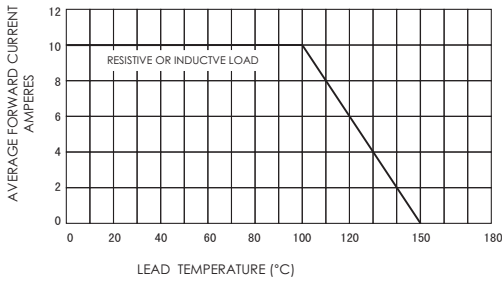

FIG.3-TYPICAL INSTANTANEOUS FORWARD CHARACTERISTICS

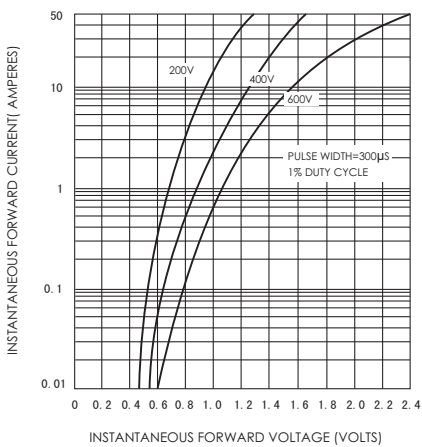

FIG.5-TYPICAL JUNCTION CAPACITANCE

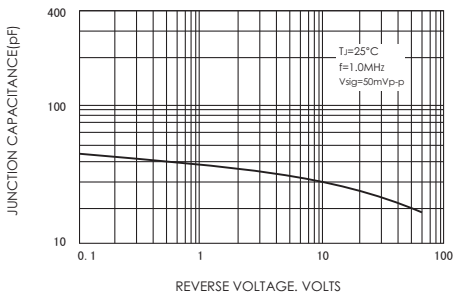

FIG.2-MAXIMUM NON-REPETITIVE PEAK FORWARD SURGE CURRENT

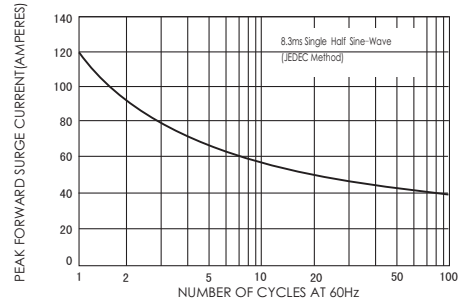

FIG.4-TYPICAL REVERSE CHARACTERISTICS

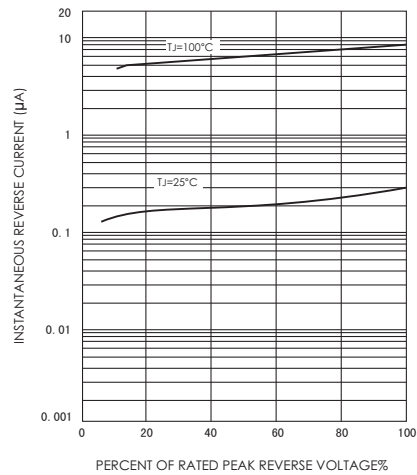

FIG.6-TYPICAL TRANSIENT THERMAL IMPEDANCE

