

FEATURES

- For general purpose applications
- These diodes features very low turn-on voltage and fast switching.
These devices are protected by a PN junction guard ring against excessive voltage, such as electrostatic discharges.
- This diode is also available in the MiniMELF case with type designation LL46.
- High temperature soldering guaranteed: 260°C / 10 seconds at terminals
- Component in accordance to RoHS 2002/95/EC and WEEE 2002/96/EC

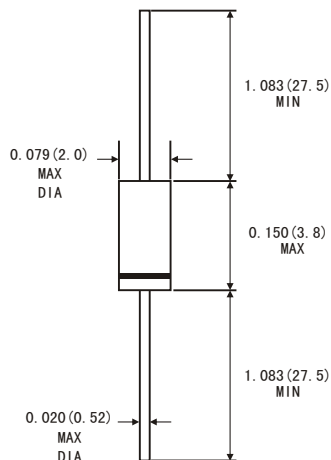

DO-35



Dimensions in inches and (millimeters)

MECHANICAL DATA

- Case: DO-35 glass case
- Polarity: color band denotes cathode end
- Weight: Approx. 0.13 gram

ABSOLUTE RATINGS(LIMITING VALUES)

	Symbols	Value	Units
Repetitive Peak Reverse Voltage	V_{RRM}	100	V
Forward Continuous Current at $T_A=25^{\circ}C$	I_F	150 ¹⁾	mA
Repetitive Peak Forward Current at $t_p < 1s, \delta < 0.5, T_A=25^{\circ}C$	I_{FRM}	350 ¹⁾	mA
Surge forward current at $t_p < 10ms, T_A=25^{\circ}C$	I_{FSM}	750 ¹⁾	mA
Power Dissipation ¹⁾ at $T_A=65^{\circ}C$	P_{tot}	150 ¹⁾	mW
Junction temperature	T_J	125	$^{\circ}C$
Ambient Operating temperature Range	T_A	-65 to +125	$^{\circ}C$
Storage Temperature Range	T_{STG}	-65 to +150	$^{\circ}C$

1) Valid provided that leads at a distance of 4mm from case are kept at ambient temperature

ELECTRICAL CHARACTERISTICS

(Ratings at 25°C ambient temperature unless otherwise specified)

	Symbols	Min.	Typ.	Max.	Unis
Reverse breakdown voltage Tested with 100μA Pulses	V(BR)R	100			V
Forward voltage Pulse Test $t_p < 300\mu s$, at $V_R=10V$, $T_J=60^\circ C$, $\delta < 2\%$ at $I_F=0.1mA$, at $I_F=10mA$, at $I_F=250mA$	V _F V _F V _F			0.255 0.45 1	V V V
Leakage current pulse test $t_p < 300\mu s$, $\delta < 2\%$ at $V_R=1.5V$, at $V_R=1.5V$, $T_J=60^\circ C$ at $V_R=10V$ at $V_R=10V$, $T_J=60^\circ C$ at $V_R=50V$ at $V_R=50V$, $T_J=60^\circ C$ at $V_R=75V$ at $V_R=75V$, $T_J=60^\circ C$	I _R I _R I _R I _R I _R I _R I _R I _R			0.5 5 0.8 7.5 2 15 5 20	μA μA μA μA μA μA μA μA
Junction Capacitance at $V_R=0V$, $f=1MHz$ at $V_R=1V$, $f=1MHz$	C _J C _J		10 6		pF pF
Thermal resistance junction to ambient Air	R _{θJA}			300 ¹⁾	K/W

1) Valid provided that leads at a distance of 4mm from case are kept at ambient temperature(DO-35)

RATINGS AND CHARACTERISTIC CURVES BAT46

Figure 1. Forward current versus forward voltage at different temperatures (typical values)

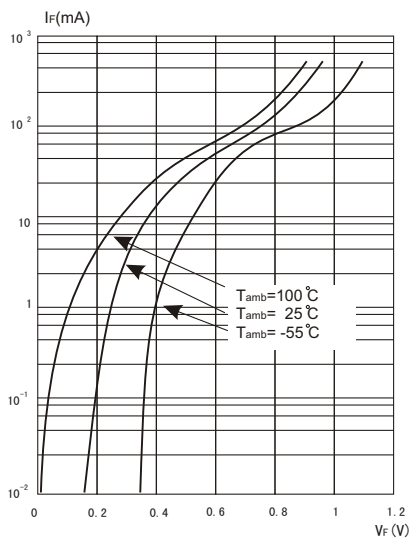

Figure 2. Forward current versus forward voltage (typical values)

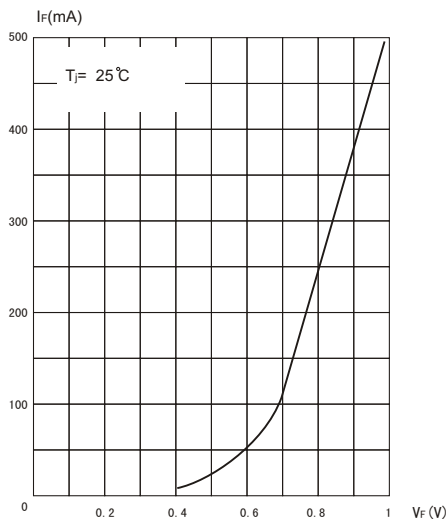
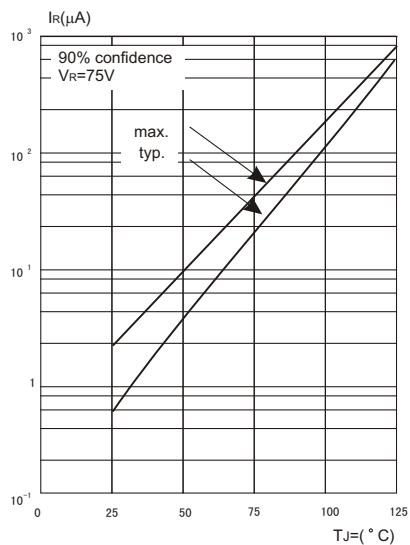

Figure 3. Reverse current versus junction temperature (typical values)



RATINGS AND CHARACTERISTIC CURVES BAT46

Figure 4. Reverse current versus continuous Reverse voltage

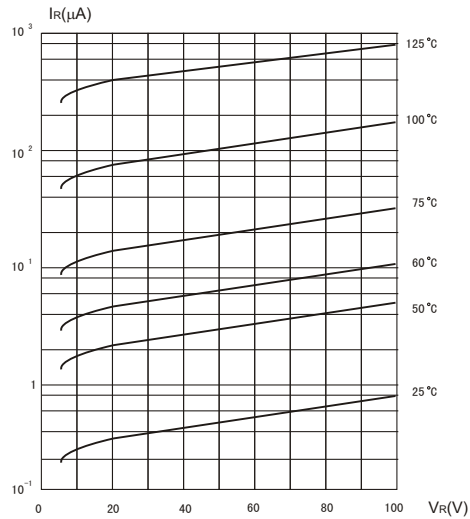

Figure 5. Capacitance C_J versus reverse applied voltage V_R (typical values)

