

Product Summary

- V_{DS} 80 V
- I_D 64 A
- I_D (Package limited) 48 A
- R_{DS(ON)} (at V_{GS} =10V) < 8.0 mohm
- R_{DS(ON)} (at V_{GS} =4.5V) < 10.0 mohm
- 100% UIS Tested
- 100% ▽V_{DS}Tested

Product Summary			
V _{DS}	R _{DS(on)} (mΩ) Typ	I _D (A)	Q _g (Typ)
80V	6.2 @ 10V	48	28.9nc

General Description

- Low R_{DS(on)} & FOM
- Extremely low Switching loss
- Excellent stability and uniformity
- Fast switching and soft recovery

Application

- Motor control
- Synchronous -rectification
- Isolated DC/DC convertor
- Invertors

DFN5060-8L

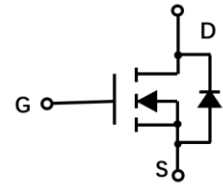
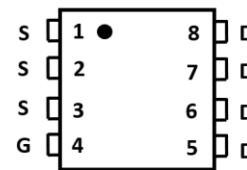
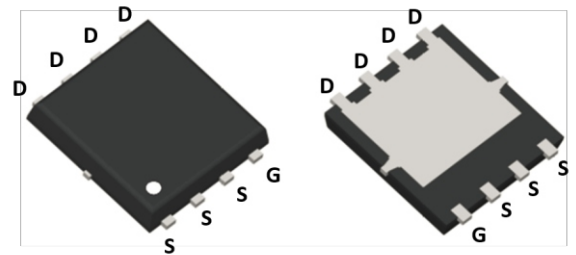

Mechanical Data

- Case:DFN5060-8L Package

Table1 Absolute Maximum Ratings (T_c=25°C, unless otherwise specified)

Parameter	Symbol	Limit	Unit
Drain-Source Voltage	V _{DS}	80	V
Gate-Source Voltage	V _{GS}	±20	V
Continuous Drain Current	I _D	T _c =25°C	48
		T _c =100°C	30.2
Pulsed Drain Current (Note 1)	I _{DM}	192	A
Single Pulse Avalanche Energy (Note 2)	E _{AS}	25	mJ
Power Dissipation	P _D	T _c =25°C	87
		T _c =100°C	35
Operating Junction and Storage Temperature	T _J /T _{STG}	-55~+175	°C

Table 2. Thermal Characteristics

Parameter	Symbol	Limit	Unit
Thermal resistance Junction to Ambient	$R_{\theta JA}$	62	$^{\circ}C/W$
Thermal resistance Junction to Case	$R_{\theta JC}$	1.72	$^{\circ}C/W$

Table 3. Electrical Characteristics ($T_J=25^{\circ}C$, unless otherwise specified)

Parameter	Symbol	Test Conditions	Min	Typ	Max	Unit	
Off Characteristics							
Drain-Source Breakdown Voltage	BV_{DSS}	$V_{GS}=0V, I_D=250\mu A$	80	-	-	V	
Drain-Source Leakage Current	I_{DSS}	$V_{DS}=80V, V_{GS}=0V$	-	-	1	μA	
Gate- Source Leakage Current	Forward	I_{GSS}	$V_{GS}=20V, V_{DS}=0V$	-	-	100	nA
	Reverse	I_{GSS}	$V_{GS}=-20V, V_{DS}=0V$	-	-	-100	nA
On Characteristics(Note 4)							
Gate Threshold Voltage	$V_{GS(TH)}$	$V_{DS}=V_{GS}, I_D=250\mu A$	1.0	1.8	2.5	V	
Static Drain-Source On-State Resistance	$R_{DS(ON)}$	$V_{GS}=10V, I_D=12A$	-	6.2	8.0	m Ω	
		$V_{GS}=4.5V, I_D=9A$	-	7.8	10		
Dynamic Characteristics(Note 5)							
Input Capacitance	C_{ISS}	$V_{DS}=25V, V_{GS}=0V, f=100KHz$	-	2028	-	pF	
Output Capacitance	C_{OSS}		-	716	-	pF	
Reverse Transfer Capacitance	C_{RSS}		-	54	-	pF	
Switching Characteristics (Note 5)							
Turn-On Delay Time	$t_d(on)$	$V_{DD}=50V, I_D=25A, V_{GS}=10V, R_G=2.5\Omega$	-	22.5	-	ns	
Turn-On Rise Time	t_R		-	6.3	-	ns	
Turn-Off Delay Time	$t_d(off)$		-	47.5	-	ns	
Turn-Off Fall Time	t_f		-	8.8	-	ns	
Total Gate Charge	Q_G	$V_{DS}=50V, I_D=25A, V_{GS}=10V$	-	28.9	-	nC	
Gate-Source Charge	Q_{GS}		-	5.4	-	nC	
Gate-Drain Charge	Q_{GD}		-	4.9	-	nC	
Drain-Source Diode Characteristics and Maximum Ratings							
Drain-Source Diode Forward Voltage	V_{SD}	$V_{GS}=0V, I_S=20A$	-	-	1.3	V	
Maximum Continuous Drain-Source Diode Forward Current	I_S		-	-	48	A	
Reverse Recovery Time	t_{rr}	$V_{GS}=0V, I_F=25A$	-	51	-	ns	
Reverse Recovery Charge	Q_{RR}	$dI_F/dt=100A/\mu s$ (Note 1)	-	61	-	nC	

Notes : 1 Repetitive Rating: Pulse width limited by maximum junction temperature

2 $L=0.3mH, V_{DD}=50V, R_G=25\Omega, \text{Starting } T_J=25^{\circ}C$

4 Pulse Test: Pulse width $\leq 300\mu s$, Duty cycle $\leq 2\%$

5 Guaranteed by design, not subject to production

Typical Test Circuit

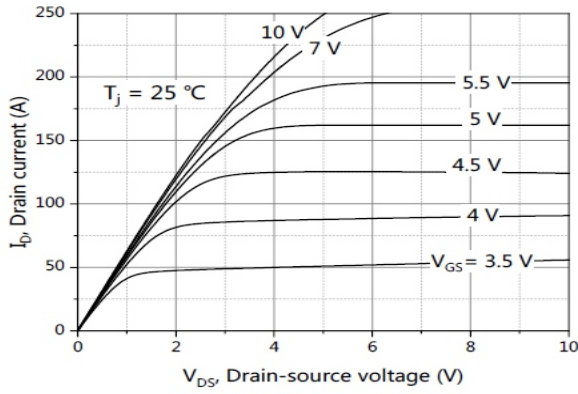

Figure1. Output Characteristics

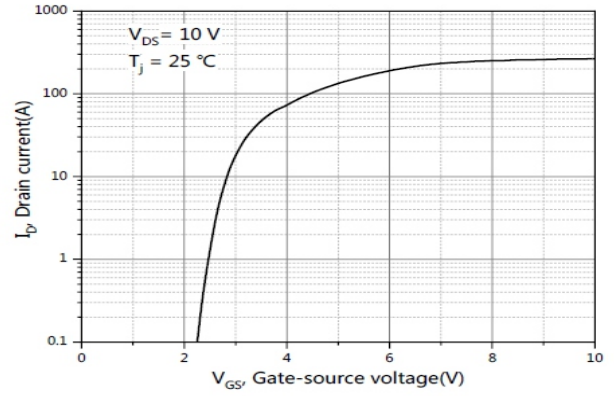

Figure2. Transfer Characteristics

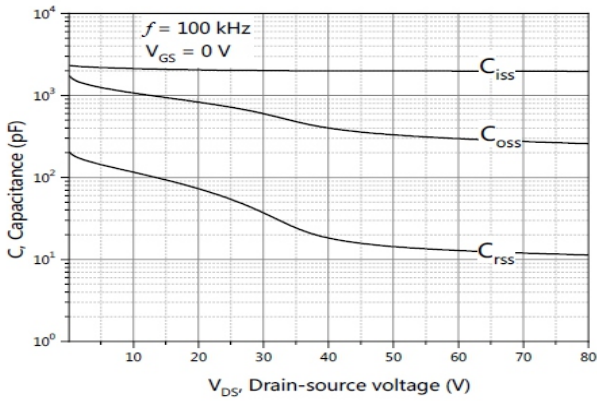

Figure3. Capacitance Characteristics

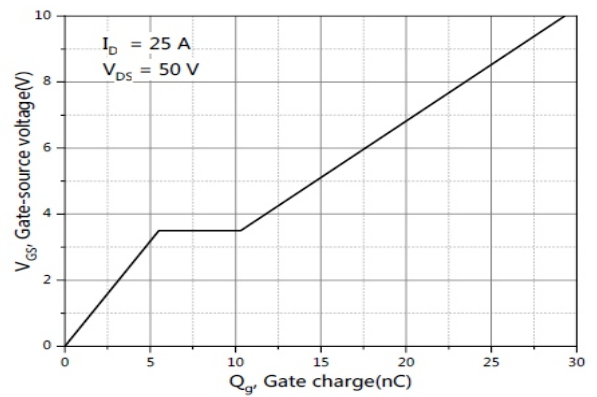

Figure4. Gate Charge

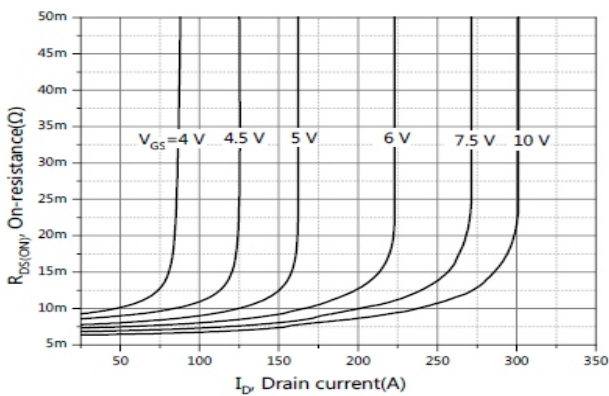

Figure5. Drain -Source on Resistance

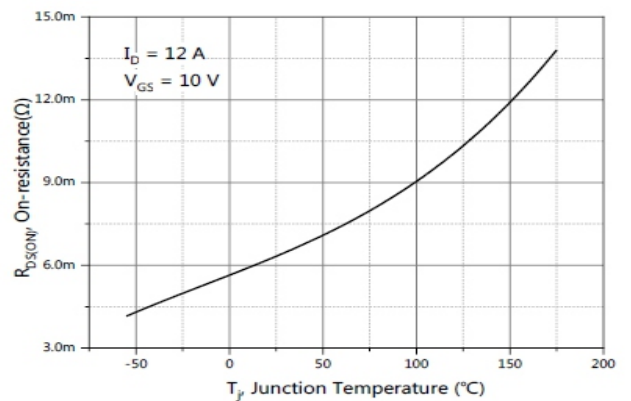

Figure6. Drain -Source on Resistance

Typical Test Circuit

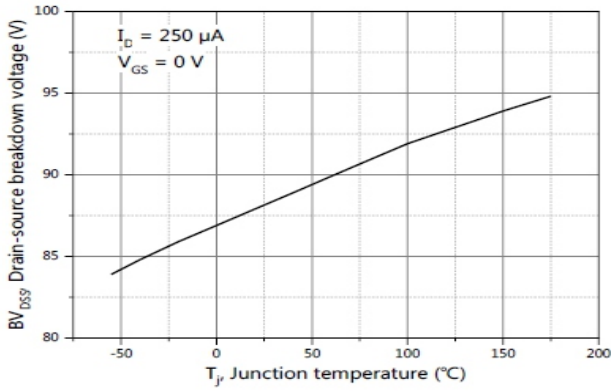

Figure7. Drain -source breakdown voltage

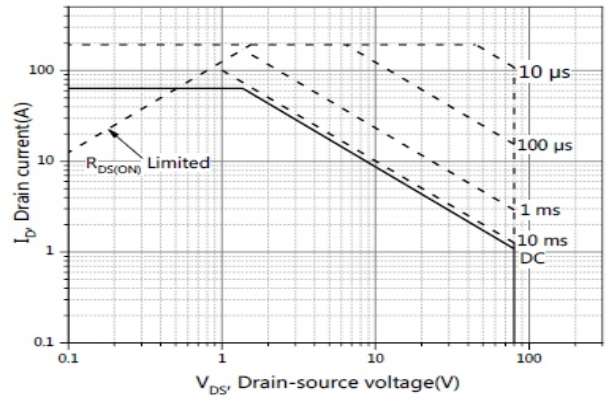

Figure8.Safe Operation Area

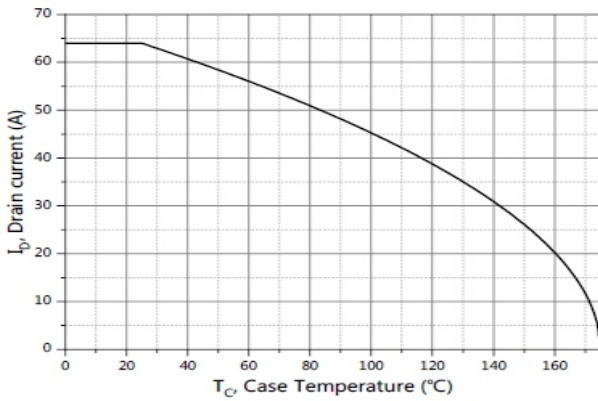

Figure9. Drain current

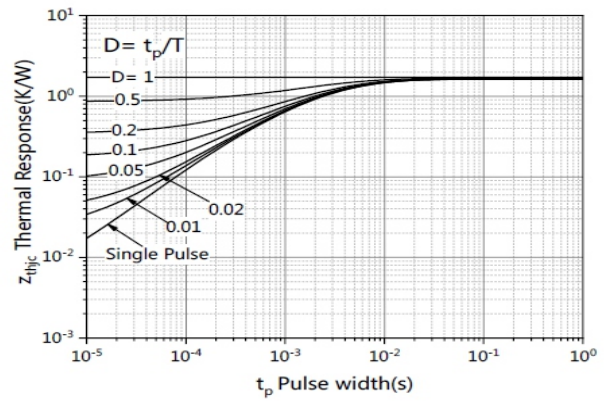
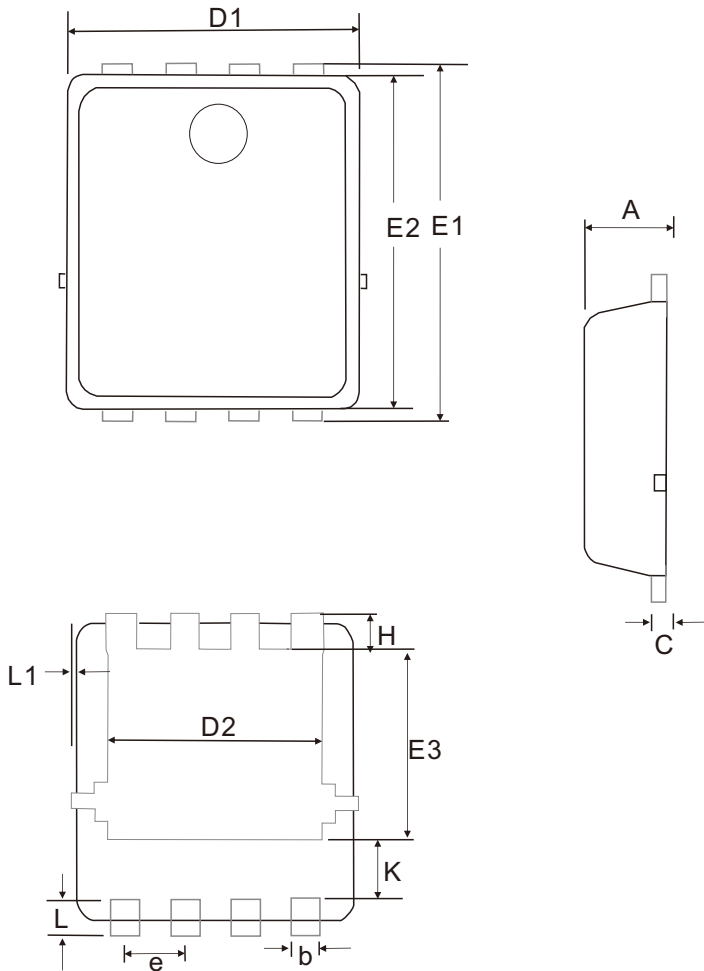

Figure10. Transient thermal impedance

Dimensions

DFN5060-8L PACKAGE OUTLINE DIMENSIONS



Symbol	Dimensions in millimeters	
	Min	Max
A	1.00	1.20
b	0.30	0.50
C	0.154	0.354
D1	5.00	5.40
D2	3.92	4.32
E1	5.95	6.35
E2	5.66	6.06
E3	3.52	3.92
e	1.17	1.37
L	0.00	0.12
L1	0.56	0.76
H	0.40	0.60
K	1.15	1.45

Friendship Reminder

┌ JiNan JingHeng hereinafter referred to as JH reserves the right to make changes to this document and its products and specifications at anytime without notice.

┌ Customers should obtain and confirm the latest product information and specifications before final design, purchase or use.

┌ JH makes no warranty, representation or guarantee regarding the suitability of its products for any particular purpose, nor does JH assume any liability for application assistance or customer product design.

┌ JH does not warrant or accept any liability with products which are purchased or used for any unintended or unauthorized application.

┌ No license is granted by implication or otherwise under any intellectual property rights of JH.

┌ JH's products are not authorized for use as critical components in life support devices or systems without express written approval of JH.