

### FEATURES

- Plastic package has Underwriters Laboratory Flammability Classification 94V-0
- Metal silicon junction ,majority carrier conduction
- Guard ring for overvoltage protection
- Low power loss ,high efficiency
- High current capability ,low forward voltage drop
- High surge capability
- High temperature soldering guaranteed:260°C/10 seconds at terminals
- Component in accordance to RoHS 2011/65/EU

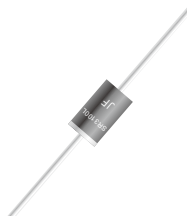

### DO-201AD

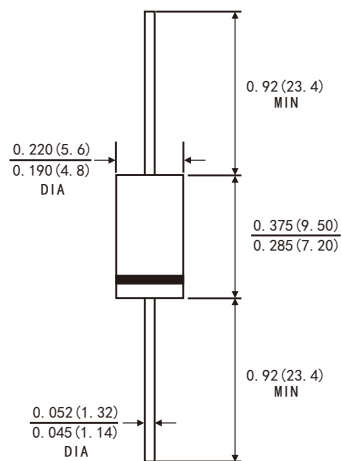

### MECHANICAL DATA

- Case: JEDEC DO-201AD molded plastic body
- Terminals: Plated axial leads, solderable per MIL-STD-750,method 2026
- Polarity: color band denotes cathode end
- Mounting Position: Any
- Weight: 0.041ounce, 1.15 grams

### TYPICAL APPLICATIONS

For use in low voltage ,high frequency inverters ,DC/DC converters, free wheeling ,and polarity protection applications

PRIMARY CHARACTERISTICS	
$I_{F(AV)}$	3.0A
$V_{RRM}$	100V
$I_{FSM}$	80A
$V_F$ at $I_F=3.0A, 25^\circ C$	0.50V
$T_{JMAX}$	150°C

### MAXIMUM RATINGS

(Ratings at 25°C ambient temperature unless otherwise specified )

Parameter	Symbol	Value	Unit
Maximum repetitive peak reverse voltage	$V_{RRM}$	100	V
Maximum average forward rectified current 0.375"(9.5mm) lead length(see fig.1)	$I_{F(AV)}$	3.0	A
Peak forward surge current 8.3ms single half sine-wave superimposed on rated load (JEDEC method at rated TL)	$I_{FSM}$	80	A
Operating junction temperature range	$T_J$	-55 to+150	°C
Storage temperature range	$T_{stg}$	-55 to+150	°C

## RATINGS AND CHARACTERISTIC OF SR3100SL

### ELECTRICAL CHARACTERISTICS (T<sub>A</sub>=25°C Unless otherwise noted)

Parameter	Test Conditions		Symbol	TYP.	MAX.	Unit
Instantaneous forward voltage	I <sub>F</sub> =3.0A	T <sub>A</sub> =25°C	V <sub>F</sub> <sup>1)</sup>	0.50	0.55	V
		T <sub>A</sub> =100°C		0.45	-	
		T <sub>A</sub> =125°C		0.43	-	
Reverse current	V <sub>R</sub> =100V	T <sub>A</sub> =25°C	I <sub>R</sub> <sup>2)</sup>	20	50	μA
		T <sub>A</sub> =100°C		2	5	mA
		T <sub>A</sub> =125°C		10	20	
Typical junction capacitance	4V, 1MHz		C <sub>J</sub>	420		pF

Notes: 1.Pulse test: 300 μs pulse width, 1% duty cycle

2.Pulse test: pulse width ≤ 40ms

### THERMAL CHARACTERISTICS (T<sub>A</sub>=25°C Unless otherwise noted)

Parameter	Symbol	DO-201AD	Unit
Typical thermal resistance <sup>3)</sup>	R <sub>θJA</sub>	25.0	°C/W
	R <sub>θJL</sub>	8.0	

3.Thermal resistance from junction to lead vertical P.C.B. mounted , 0.375"(9.5mm)lead length

### AVAILABLE PACK INFORMATION

Product code	Pack	Box Size L*W*H(mm)	Quantity (pcs/box)	Carton Size L*W*H(mm)	Quantity (box/carton)
SR3100SL-DO-201AD	B/P	190*80*21	200	433*203*230	50
SR3100SL-DO-201AD	T/B	264*74*135	1000	400*267*286	10

# RATINGS AND CHARACTERISTIC OF SR3100SL

FIG.1-FORWARD CURRENT DERATING CURVE

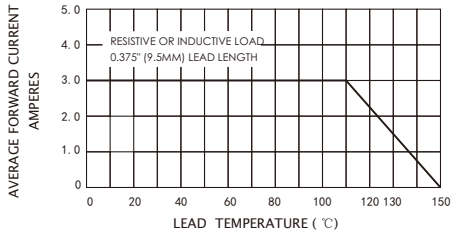

FIG.2-MAXIMUM NON-REPETITIVE PEAK FORWARD SURGE CURRENT

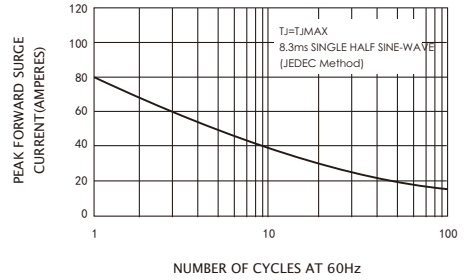

FIG.3-TYPICAL INSTANTANEOUS FORWARD CHARACTERISTICS

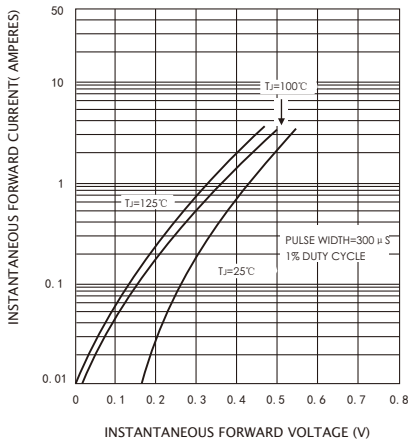

FIG.4-TYPICAL REVERSE CHARACTERISTICS

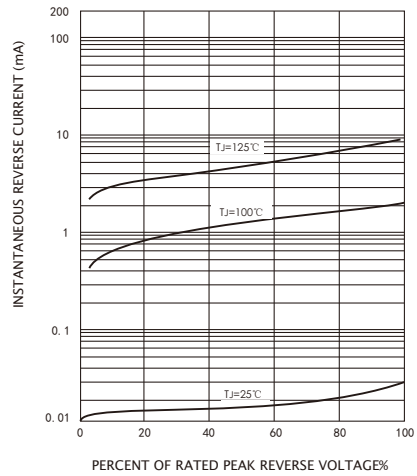

FIG.5-TYPICAL JUNCTION CAPACITANCE

