

Features

- High blocking voltage with low on-resistance
- High speed switching with low capacitance
- High operating junction temperature capability
- Very fast and robust intrinsic body diode
- Kelvin gate input easing driver circuit design

Product Summary			
V _{DS}	R _{DS(on)} (mΩ)Typ	I _D (A)	Q _g (Typ)
1200V	40 @ 18V 20A	65	110nc

SOT-227

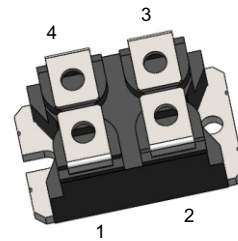

Mechanical Data

- Case:SOT-227 Package

Application

- Motor drivers
- Solar inverters
- Automotive DC/DC converters
- Automotive compressor inverters
- Switch mode power supplies

Block Diagram

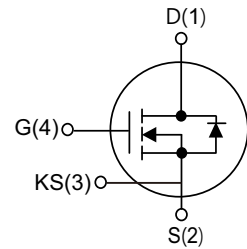

Table1 Absolute Maximum Ratings (T_c=25°C, unless otherwise specified)

Parameter	Symbol	Value	Unit
Drain-Source Voltage	V _{DS}	1200	V
Gate-Source Voltage(Max)	V _{GS(DC)}	-5/+20	V
Gate-Source Voltage(Max)	V _{GS (Spike)}	-10/+23	V
Continuous Drain Current	I _D	T _C =25°C	65
		T _C =100°C	48
Pulsed Drain Current (Note 1)	I _{DM}	162	A
Recommended turn-on voltage	V _{GSon}	18±0.5	V
Recommended turn-off voltage	V _{GSoff}	-3.5/-2	V
Power Dissipation T _C =25°C	P _D	417	W
Operating Junction and Storage Temperature	T _J /T _{STG}	-55 ~ +175	°C

Table 2.Thermal Characteristics

Parameter	Symbol	SC40N120S7P	Unit
Thermal resistance Junction to Case	R _{θJC}	0.36	°C/W

Table 3. Electrical Characteristics ($T_J=25^{\circ}\text{C}$, unless otherwise specified)

Parameter	Symbol	Test Conditions	Min	Typ	Max	Unit	
Off Characteristics							
Drain-Source Breakdown Voltage	BV_{DSS}	$V_{GS}=0V, I_D=1mA$	1200	-	-	V	
Drain-Source Leakage Current	I_{DSS}	$V_{DS}=1200V, V_{GS}=0V$	-	-	100	μA	
Gate- Source Leakage Current	Forward	I_{GSS}	$V_{GS}=20V, V_{DS}=0V$	-	-	100	nA
	Reverse	I_{GSS}	$V_{GS}=-5V, V_{DS}=0V$	-	-	-100	nA
On Characteristics							
Gate Threshold Voltage	$V_{GS(TH)}$	$V_{DS}=V_{GS}, I_D=9mA$	1.8	2.8	4.5	V	
Static Drain-Source On-State Resistance	$R_{DS(ON)}$	$V_{GS}=18V, I_D=20A, T_J=25^{\circ}\text{C}$	-	40	52	m Ω	
		$V_{GS}=18V, I_D=20A, T_J=175^{\circ}\text{C}$	-	75	-		
Gate Resisitance	R_G	$f=1\text{MHz}$	-	2.1	-	Ω	
Dynamic Characteristics							
Input Capacitance	C_{ISS}	$V_{DS}=800V, V_{GS}=0V, f=1\text{MHz}, V_{AC}=25\text{mV}$	-	2160	-	pF	
Output Capacitance	C_{OSS}		-	100	-	pF	
Reverse Transfer Capacitance	C_{RSS}		-	5.8	-	pF	
Coss stored energy	E_{OSS}		-	40	-	μJ	
Turn-on switching energy	E_{ON}	$V_{DS}=800V, I_D=30A, V_{GS}=-3.5/18V, R_G=3.3\Omega, L=200\mu\text{H}, T_J=25^{\circ}\text{C}$	-	446.3	-	μJ	
Turn-off switching energy	E_{OFF}		-	70	-	μJ	
Turn-On Delay Time	$t_{d(on)}$		-	9.6	-	ns	
Turn-On Rise Time	t_r		-	22.1	-	ns	
Turn-Off Delay Time	$t_{d(off)}$		-	19.3	-	ns	
Turn-Off Fall Time	t_f		-	10.5	-	ns	
Total Gate Charge	Q_G	$V_{DD}=800V, I_D=30A, V_{GS}=-3/18V$	-	110	-	nC	
Gate-Source Charge	Q_{GS}		-	25	-	nC	
Gate-Drain Charge	Q_{GD}		-	59	-	nC	
Drain-Source Diode Characteristics and Maximum Ratings(Note 2)							
Drain-Source Diode Forward Voltage	V_{SD}	$V_{GS}=0V, I_S=20A$	-	4.2	-	V	
Reverse Recovery Time	t_{rr}	$V_{GS}=-3.5V/+18V, V_R=800V, R_G(\text{ext})=10\Omega, L=200\mu\text{H}$	-	42	-	ns	
Recovered charge	Q_{rr}	$I_{SD}=30A, diF/dt=3000A/\mu\text{s}$	-	198.1	-	nC	
Peak reverse recovery current	I_{rrm}		-	17.4	-	A	

Notes: 1 Repetitive Rating Pulse width limited by maximum junction temperature

 2 Pulse Test: Pulse width $\leq 300\mu\text{s}$, Duty cycle $\leq 2\%$

Typical Characteristics Diagrams

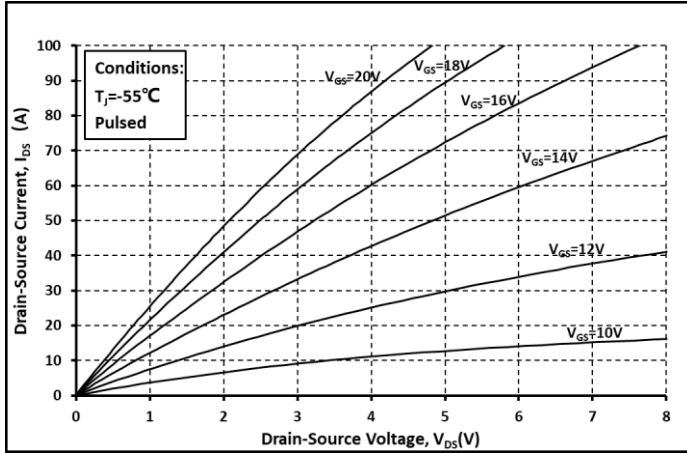

Fig. 1 Output Curve @ $T_j = -55^\circ\text{C}$

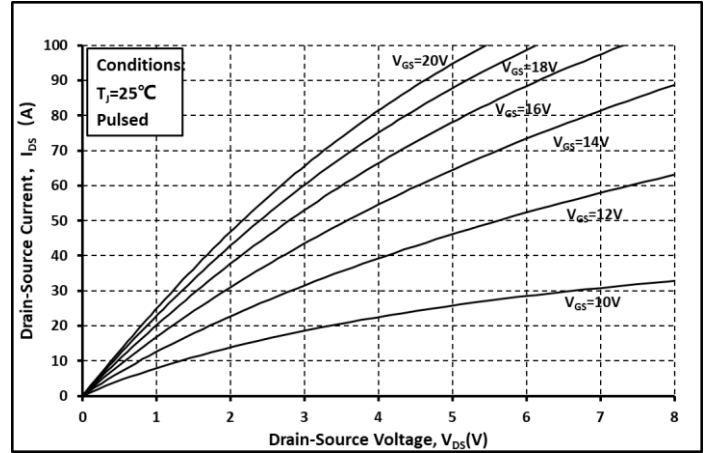

Fig. 2 Output Curve @ $T_j = 25^\circ\text{C}$

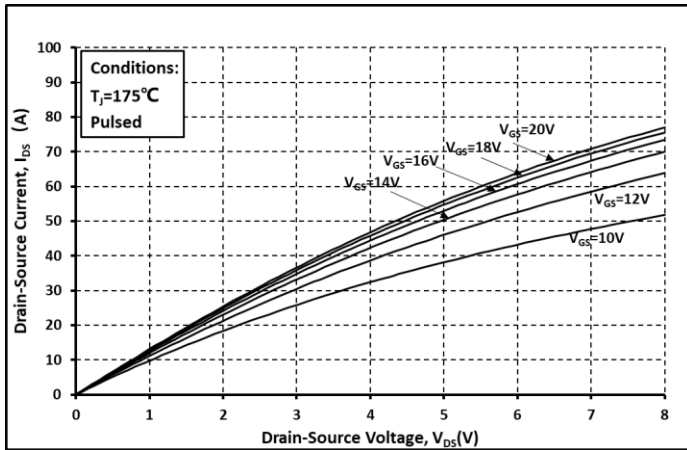

Fig. 3 Output Curve @ $T_j = 175^\circ\text{C}$

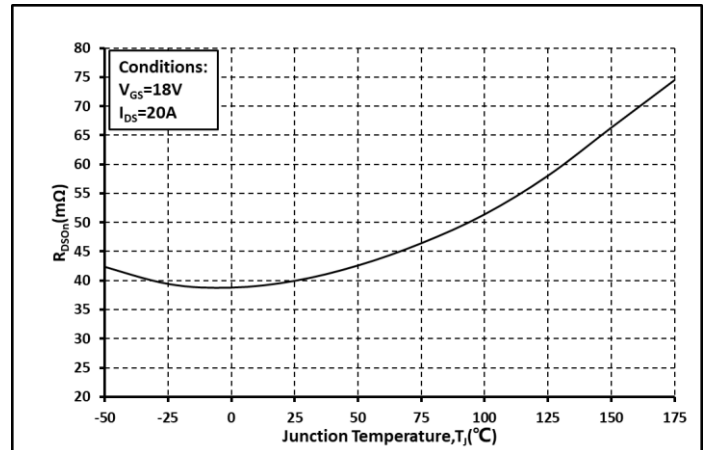

Fig. 4 R_{on} vs. Temperature

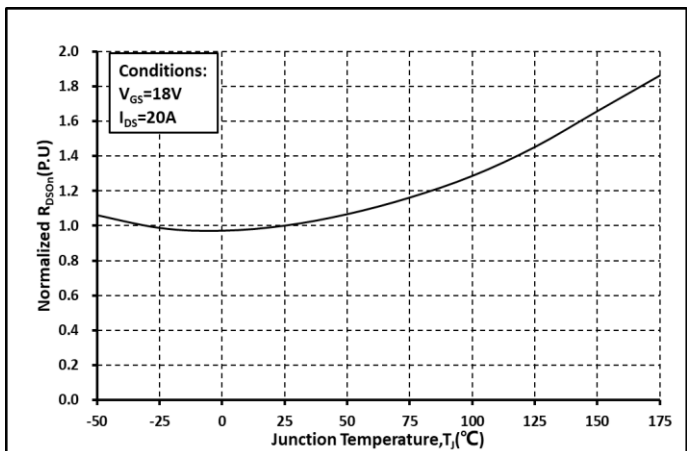

Fig. 5 Normalized R_{on} vs. Temperature

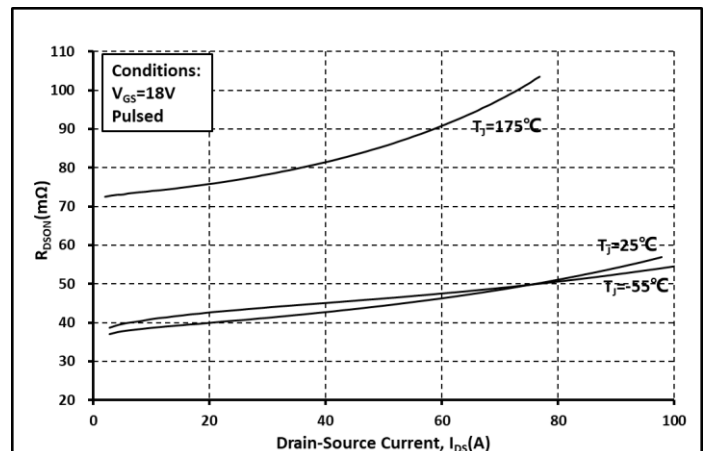

Fig. 6 R_{on} vs. I_{DS} @ Various Temperature

Typical Characteristics Diagrams

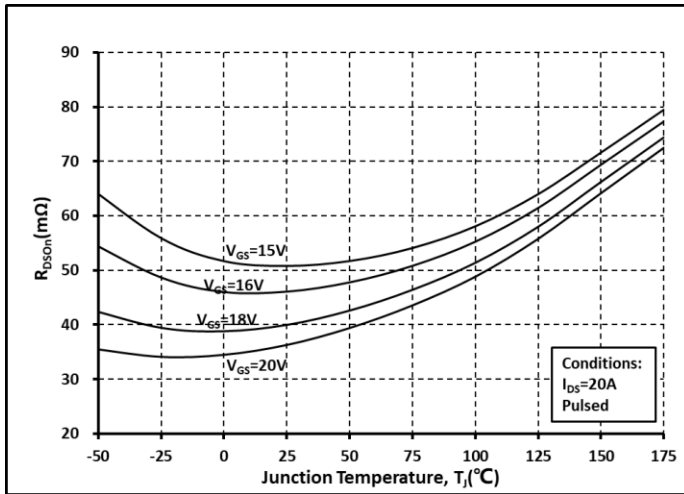

Fig. 7 Ron vs. Temperature @ Various V_{GS}

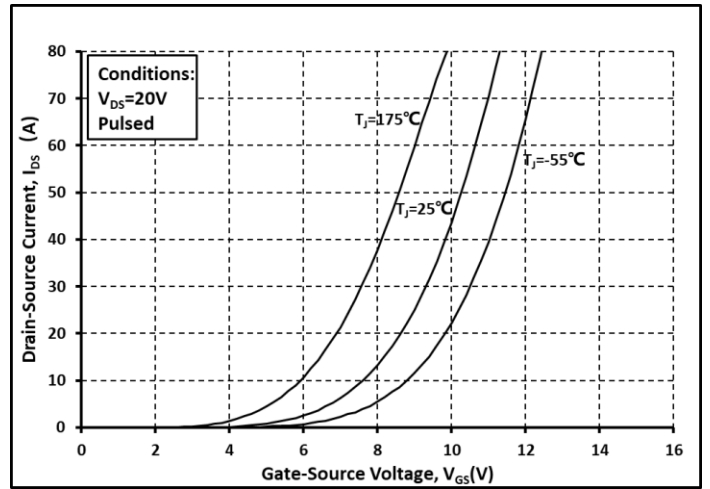

Fig. 8 Transfer Curves @ Various Temperature

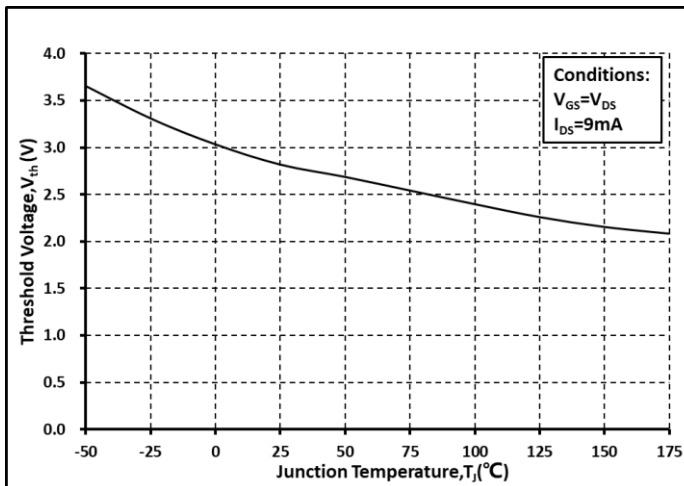

Fig. 9 Threshold Voltage vs. Temperature

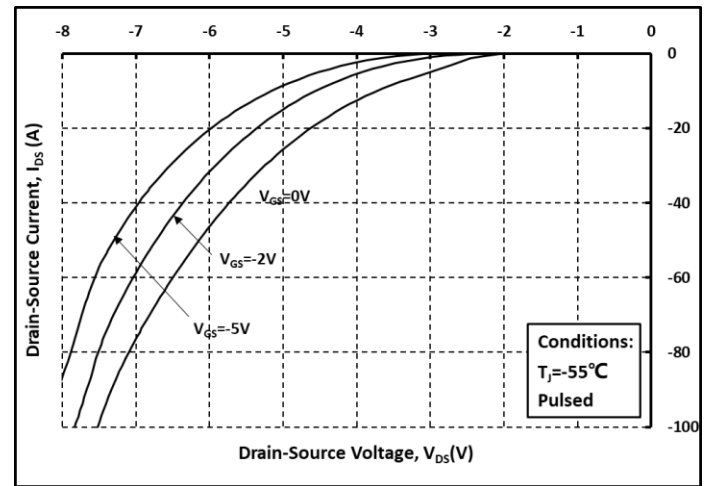

Fig. 10 Body Diode curves @ $T_j = -55^\circ\text{C}$

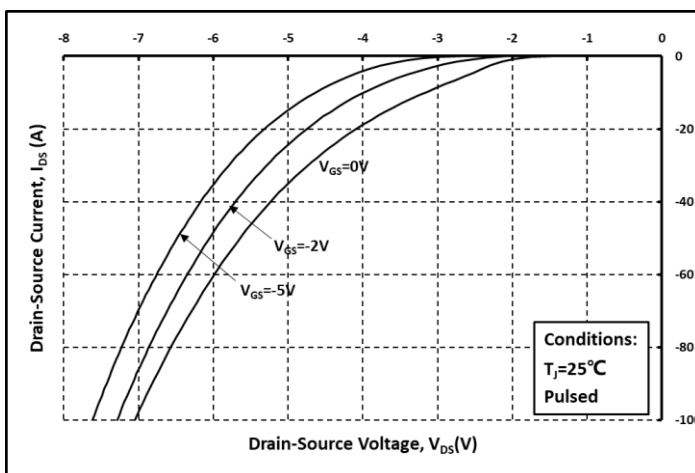

Fig. 11 Body Diode curves @ $T_j = 25^\circ\text{C}$

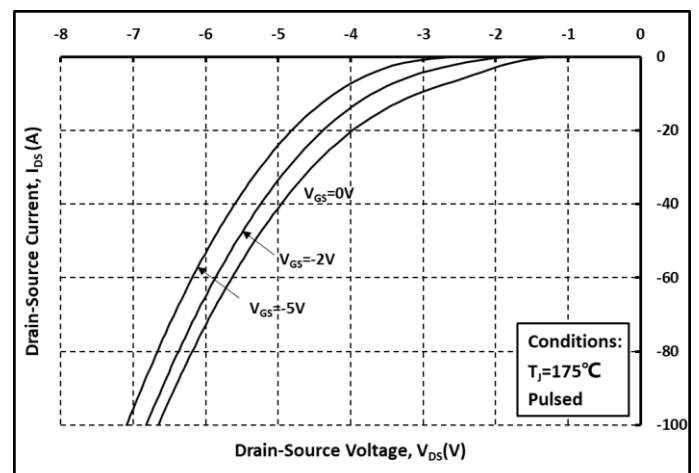

Fig. 12 Body Diode curves @ $T_j = 175^\circ\text{C}$

Typical Characteristics Diagrams

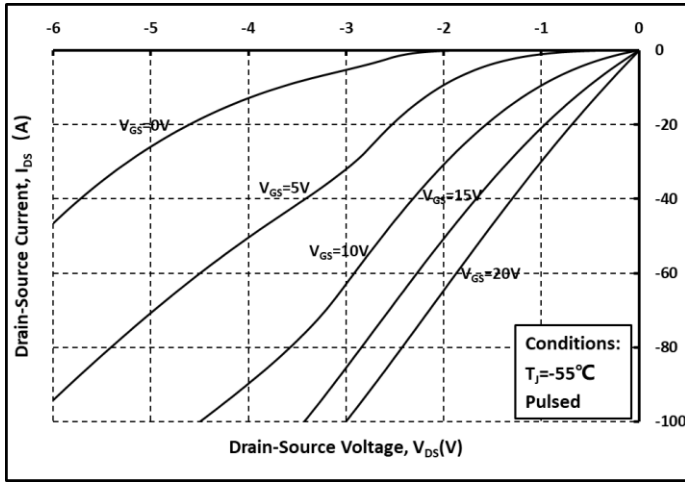

Fig. 13 3rd Quadrant curves @ $T_j = -55^\circ\text{C}$

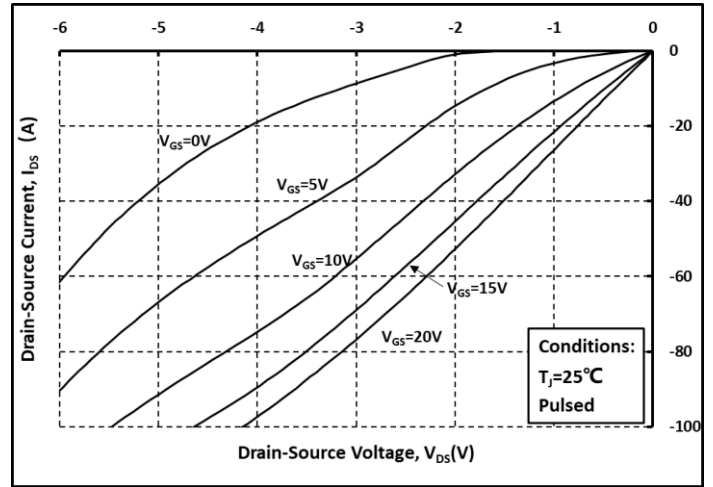

Fig. 14 3rd Quadrant curves @ $T_j = 25^\circ\text{C}$

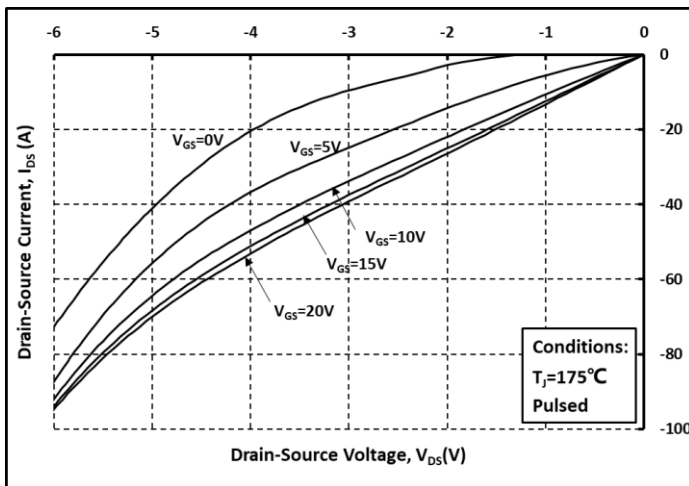

Fig. 15 3rd Quadrant curves @ $T_j = 175^\circ\text{C}$

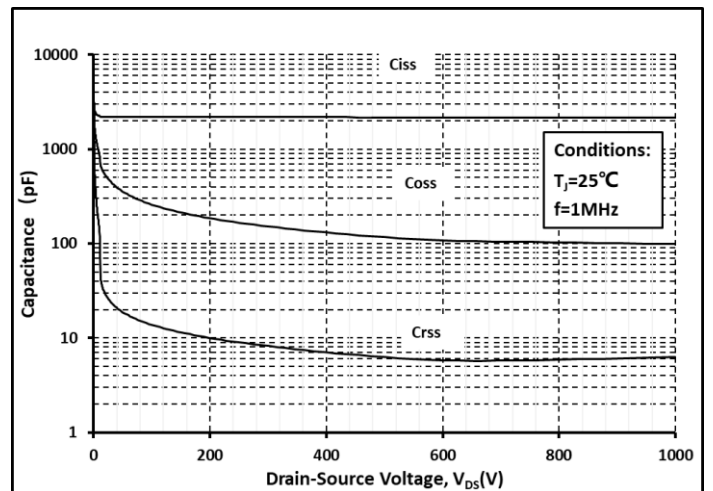

Fig. 16 Capacitance vs. V_{DS}

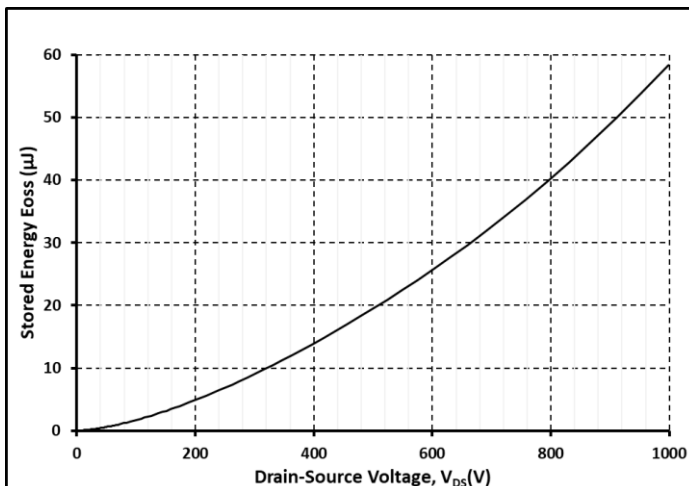

Fig. 17 Output Capacitor Stored Energy

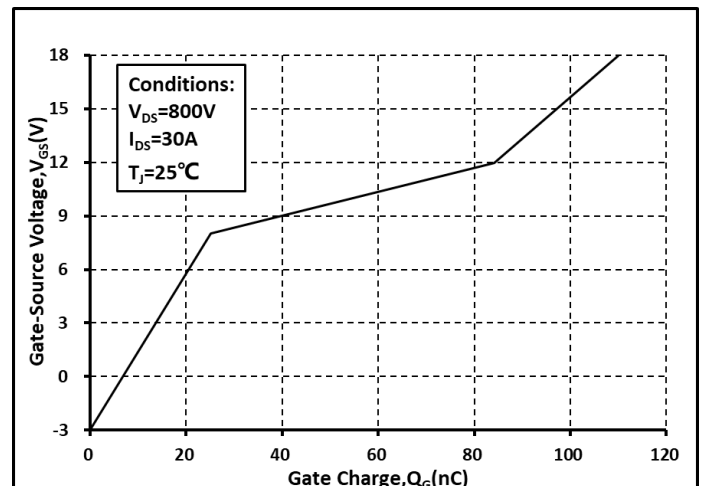

Fig. 18 Gate Charge Characteristics

Typical Characteristics Diagrams

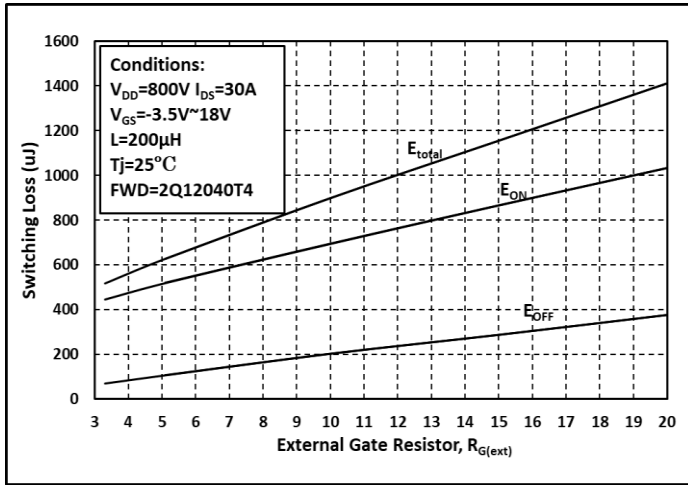

Fig. 19 Switching Energy vs. $R_{G(ext)}$

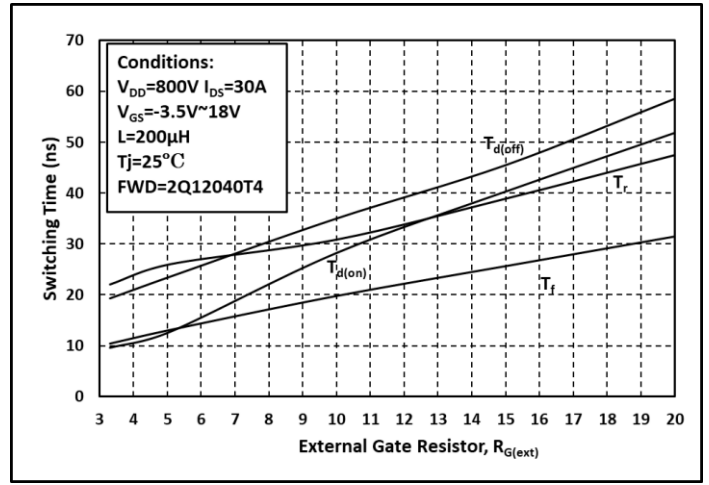

Fig. 20 Switching Times vs. $R_{G(ext)}$

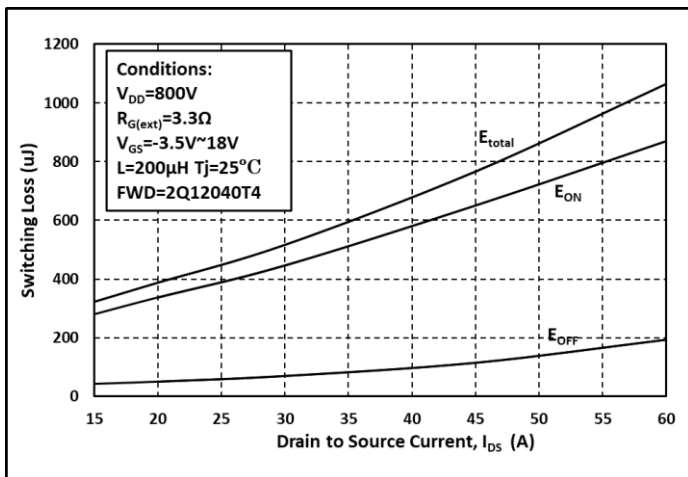

Fig. 21 Switching Energy vs. I_{DS}

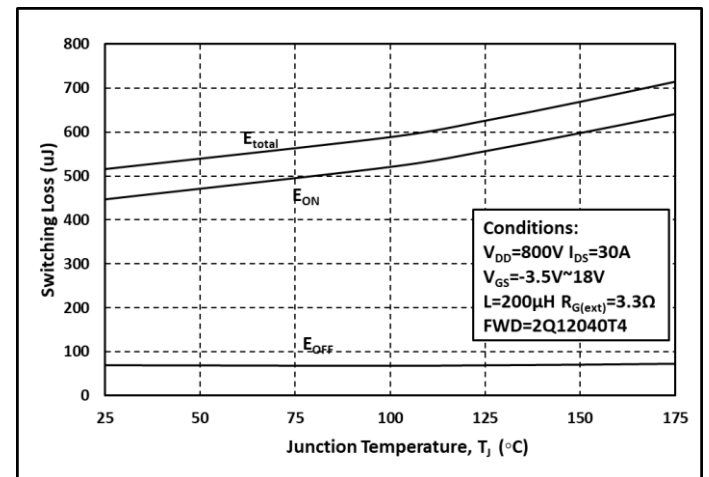

Fig. 22 Switching Energy vs. Temperature

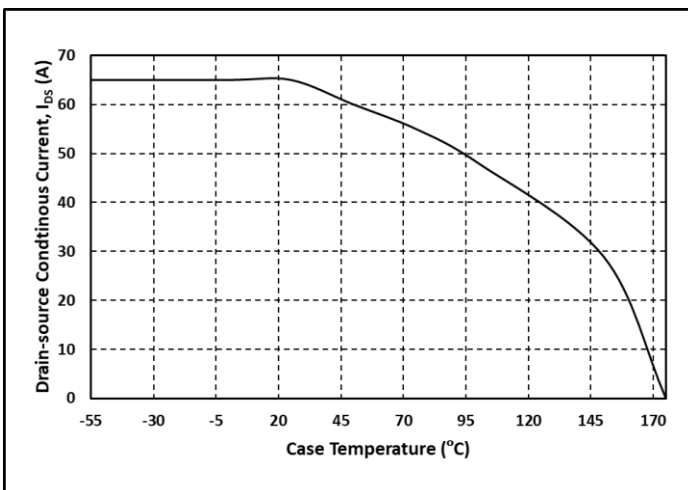

Fig. 23 Continuous Drain Current vs. Case Temperature

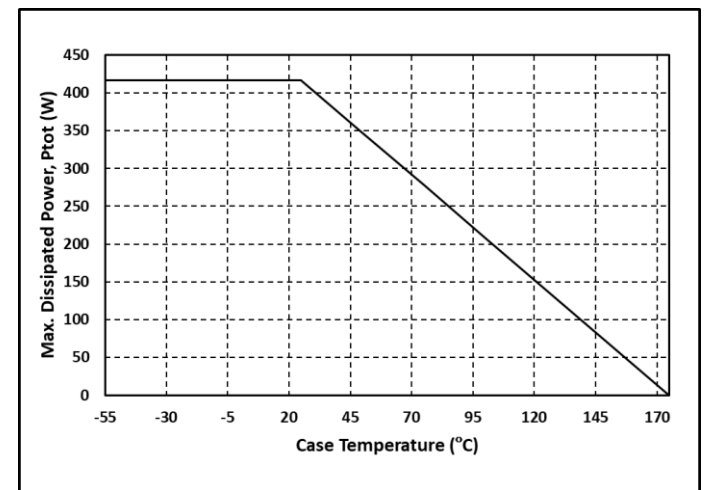

Fig. 24 Max. Power Dissipation Derating vs. Case Temperature

Typical Characteristics Diagrams

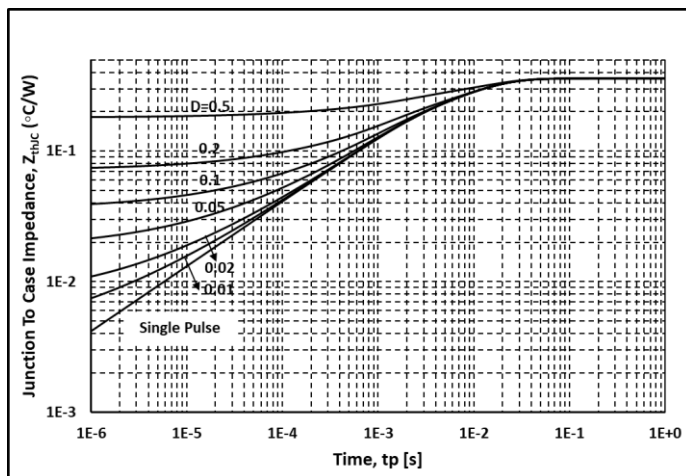

Fig. 25 Thermal impedance

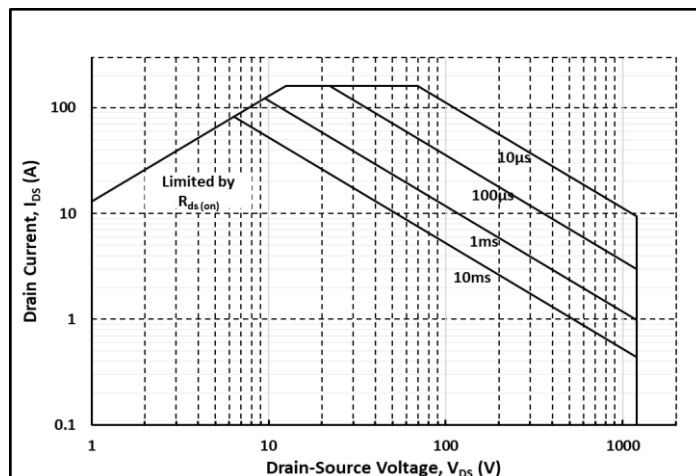
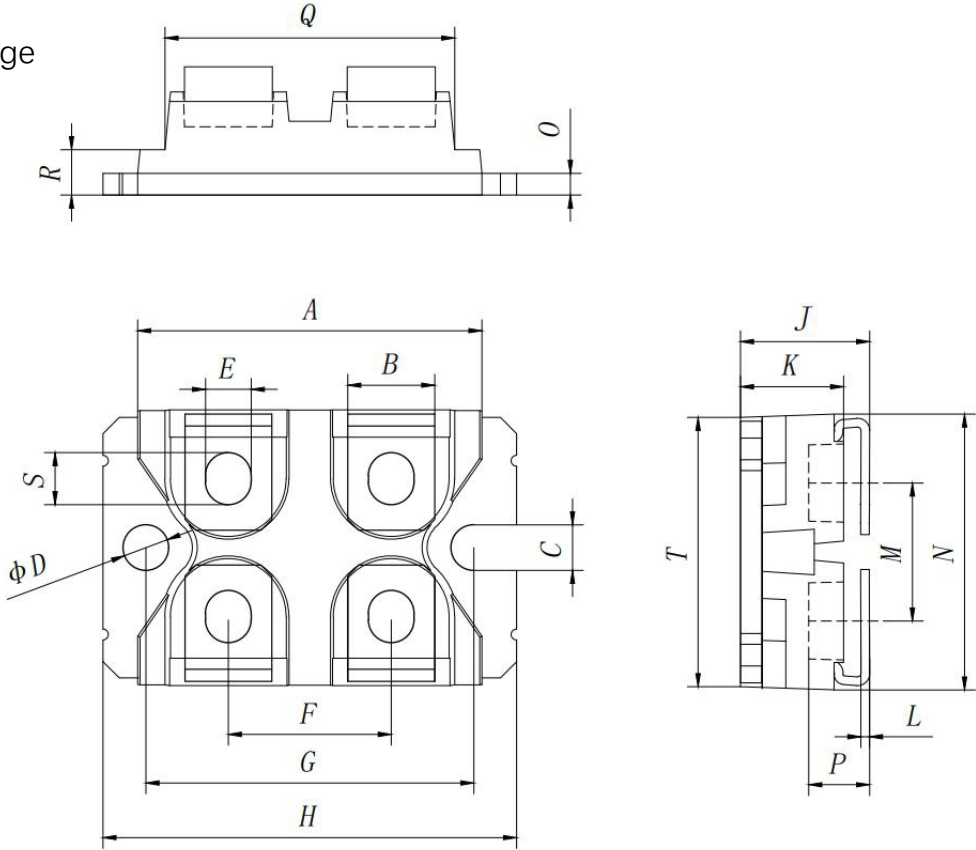

Fig. 26 Safe Operating Area

Dimensions

SOT-227 package



SYMBOLS	DIMENSION IN MM		
	MIN	NOM	MAX
A	31.20	31.70	32.20
B	7.50	8.00	8.50
C	3.80	4.20	4.60
D	3.80	4.20	4.60
E	3.80	4.20	4.60
F	14.50	15.00	15.50
G	29.80	30.20	30.60
H	37.70	38.10	38.50
J	11.50	11.90	12.30
K	8.90	9.50	10.00
L	0.75	0.80	0.85
M	12.40	12.70	13.00
N	25.00	25.40	25.80
O	1.70	2.00	2.30
P	4.95	5.60	6.10
Q	26.40	26.70	27.00
R	3.90	4.18	4.45
S	4.20	4.80	5.40
T	23.80	24.80	25.80

Friendship Reminder

- JiNan JingHeng (hereinafter referred to as JH) reserves the right to make changes to this document and its products and specifications at anytime without notice.
- Customers should obtain and confirm the latest product information and specifications before final design, purchase or use.
- JH makes no warranty, representation or guarantee regarding the suitability of its products for any particular purpose, nor does JH assume any liability for application assistance or customer product design.
- JH does not warrant or accept any liability with products which are purchased or used for any unintended or unauthorized application.
- No license is granted by implication or otherwise under any intellectual property rights of JH.
- JH's products are not authorized for use as critical components in life support devices or systems without express written approval of JH.