

### Features

- Plastic package has Underwriters Laboratory Flammability Classification 94V-0
- Metal silicon junction ,majority carrier conduction
- Guard ring for overvoltage protection
- Low power loss ,high efficiency
- High current capability ,Low forward voltage drop
- High surge capability
- For use in low voltage ,high frequency inverters, free wheeling ,and polarity protection applications
- Dual rectifier construction
- High temperature soldering guaranteed:260° C/10 seconds, 0.25"(6.35mm)from case
- Component in accordance to RoHS 2015/863/EU

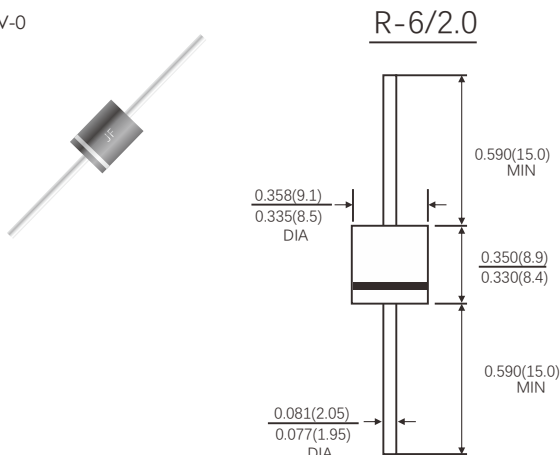

Dimensions in inches and (millimeters)

### Mechanical Data

- Case: R-6/2.0 molded plastic body
- Terminals: Plated axial lead, solderable per MIL-STD-750,method 2026
- Polarity: Color band denotes cathode end
- Mounting Position: Any
- Weight: 0.07ounce, 2.1 grams

### Maximum Ratings And Electrical Characteristics

(Ratings at 25°C ambient temperature unless otherwise specified ,single phase ,half wave ,resistive or inductive load. For capacitive load,derate by 20%.)

Parameter	Symbols	30SQ045	Units
Maximum repetitive peak reverse voltage	V <sub>RRM</sub>	45	Volts
Maximum RMS voltage	V <sub>RMS</sub>	32	Volts
Maximum DC blocking voltage	V <sub>DC</sub>	45	Volts
Maximum average forward rectified current 0.375"(9.5mm) lead length(see fig.1)	I(AV)	35.0	Amps
Peak forward surge current 8.3ms single half sine-wave superimposed on rated load (JEDEC method at rated T <sub>J</sub> )	I <sub>FSM</sub>	450	Amps
Maximum instantaneous forward voltage at 35.0 A(Note 1)	V <sub>F</sub>	0.55	Volts
Maximum instantaneous reverse current at rated DC blocking voltage(Note 1)	I <sub>R</sub>	T <sub>a</sub> =25°C	0.1
		T <sub>a</sub> =100°C	20
Typical thermal resistance (Note 2)	R <sub>θJC</sub>	1.0	°C/W
	R <sub>θJA</sub>	45	
Operating junction temperature range at reduced reverse voltage V <sub>R</sub> <=80%V <sub>RRM</sub> in DC forward model	T <sub>J</sub>	-55 to+150	°C
		-55 to+200	
Storage temperature range	T <sub>STG</sub>	-55 to+150	°C

**Notes:** 1.Pulse test: 300μ s pulse width,1% duty cycle

2.Thermal resistance from junction to case, Thermal resistance from junction to lead,  
Thermal resistance from junction to ambient

FIG.1-FORWARD CURRENT DERATING CURVE

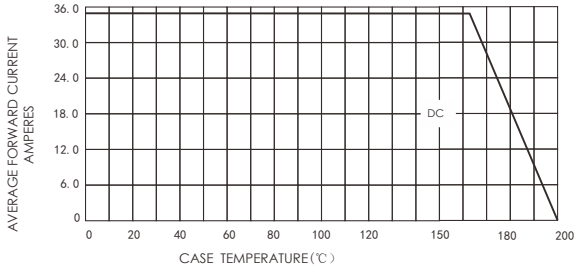

FIG.2-MAXIMUM NON-REPETITIVE PEAK FORWARD SURGE CURRENT

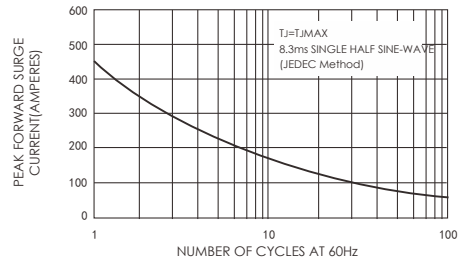

FIG.3-TYPICAL INSTANTANEOUS FORWARD CHARACTERISTICS

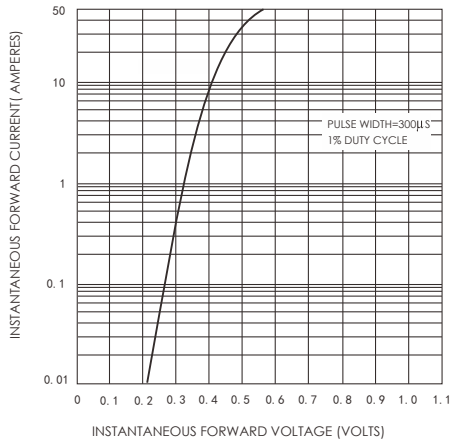
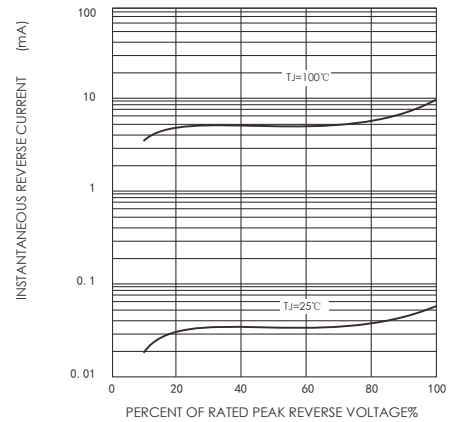

FIG.4-TYPICAL REVERSE CHARACTERISTICS



## Friendship Reminder

- JiNan JingHeng (hereinafter referred to as JH) reserves the right to make changes to this document and its products and specifications at anytime without notice.
  
- Customers should obtain and confirm the latest product information and specifications before final design, purchase or use.
  
- JH makes no warranty, representation or guarantee regarding the suitability of its products for any particular purpose, nor does JH assume any liability for application assistance or customer product design.
  
- JH does not warrant or accept any liability with products which are purchased or used for any unintended or unauthorized application.
  
- No license is granted by implication or otherwise under any intellectual property rights of JH.
  
- JH's products are not authorized for use as critical components in life support devices or systems without express written approval of JH.