

SC1065CT SC1065D1

SILICON CARBIDE SCHOTTKY DIODE
Reverse Voltage - 650 Volts
Forward Current - 10.0Amperes

DESCRIPTION

SiC Schottky Diode has no switching loss, provides improved system efficiency against Si diodes by utilizing new semiconductor material-Silicon Carbide, enables higher operating frequency, and helps increasing power density and reduction of system size /cost. Its high reliability ensures robust operation during surge or over-voltage conditions.

FEATURES

- Max Junction Temperature 175°C
- High Surge Current Capacity
- Positive Temperature Coefficient
- Ease of Paralleling
- No Reverse Recovery/No Forward Recovery

MECHANICAL DATA

- Case: JEDEC TO-220AB/TO-263AB
- Molding compound meets UL94V-0 flammability rating
- Terminals: Lead solderable per J-STD-002 and JESD22-B102
- Polarity: As marked
- Mounting Torque: 10 in-lbs maximum

TYPICAL APPLICATIONS

- General Purpose
- SMPS, Solar inverter, UPS
- Power Switching Circuits

MAXIMUM RATINGS

(Ratings at 25°C ambient temperature unless otherwise specified)

Parameter	Symbol	SC1065CT SC1065D1	Unit
Maximum repetitive peak reverse voltage	V_{RRM}	650	V
Continuous Rectified Forward Current	I_F	10	A
Repetitive Forward Surge Current (NOTE 1)	$I_{F, RM}$	40	A
Operating junction temperature range	T_J	-55 to+175	°C
Storage temperature range	T_{stg}	-55 to+175	°C

Notes: 1.Half-Sine Pulse, $t_p=8.3ms$

TO-220AB

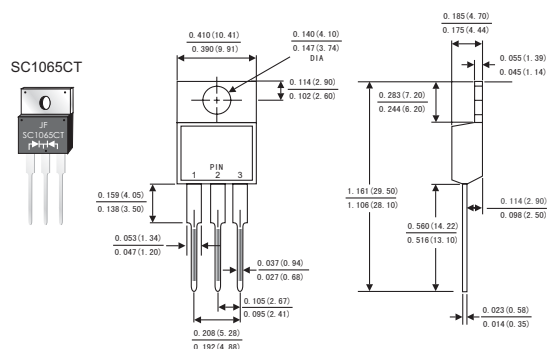

Dimensions in inches and (millimeters)

TO-263AB D2PAK

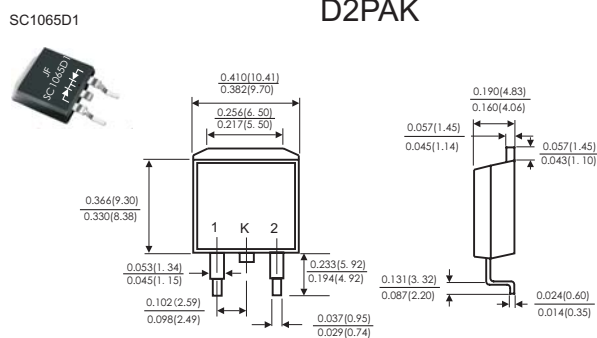

Dimensions in inches and (millimeters)

RATINGS AND CHARACTERISTIC OF SC1065CT SC1065D1

ELECTRICAL CHARACTERISTICS (T_A=25°C Unless otherwise noted)

Parameter	Test Conditions		Symbol	TYP.	MAX.	Unit
Instaneous forward voltage	I _F =10A	T _A =25°C	V _F	1.30	1.6	V
		T _A =175°C		1.50	1.8	
Reverse current	V _R =650V	T _A =25°C	I _R	-	10	μA
		T _A =125°C		-	40	
		T _A =175°C		-	100	
Typical junction capacitance	V _R =1V, f=100kHz		C _j	650	-	pF
	V _R =4V, f=100kHz			450	-	
	V _R =40V, f=100kHz			160	-	

THERMAL CHARACTERISTICS (T_A=25°C Unless otherwise noted)

Parameter	Symbol	SC1065CT SC1065D1	Unit
Typical thermal resistance ²⁾	R _{θJC}	2.5	°C/W

2.Thermal resistance from junction to case

RATINGS AND CHARACTERISTIC OF SC1065CT SC1065D1

FIG.1-FORWARD CURRENT DERATING CURVE

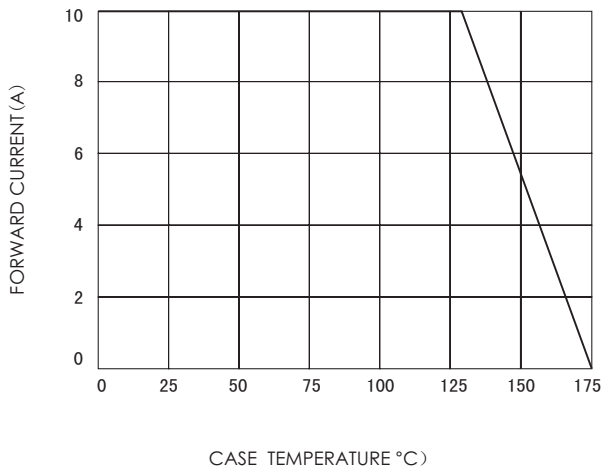

FIG.2-FORWARD CURRENT DERATING CURVE

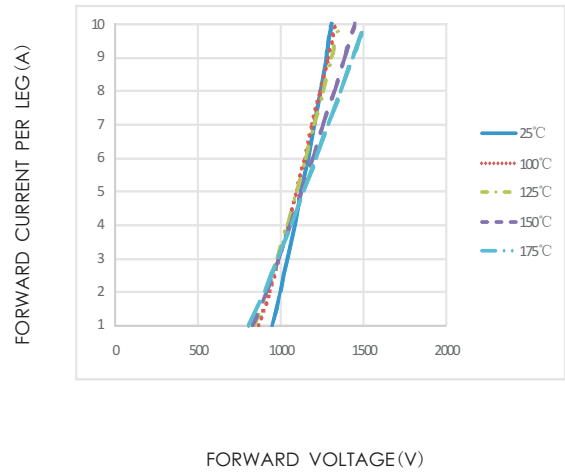

FIG.3-TYPICAL JUNCTION CAPACITANCE

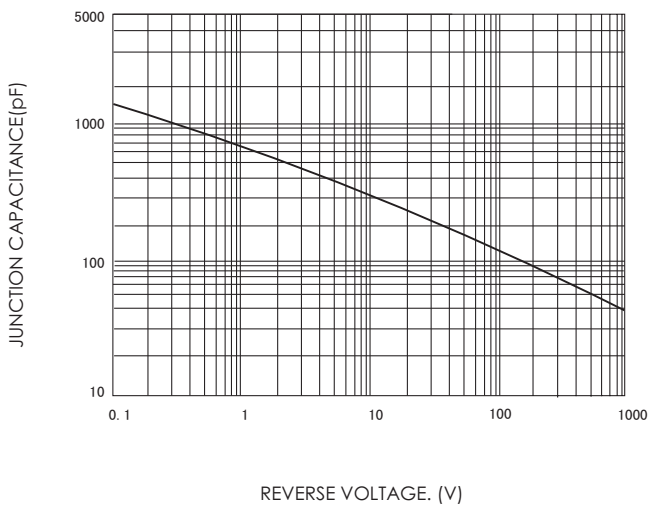

FIG.4-REVERSE CHARACTERISTICS

