

FEATURES

- Plastic package has Underwriters Laboratory Flammability Classification 94V-0
- Metal silicon junction ,majority carrier conduction
- Guard ring for overvoltage protection
- Low power loss ,high efficiency
- High current capability ,low forward voltage drop
- High surge capability
- High temperature soldering guaranteed:260°C/10 seconds at terminals
- Component in accordance to RoHS 2011/65/EU and WEEE 2012/19/EU



RoHS
COMPLIANT



SMA(DO-214AC)

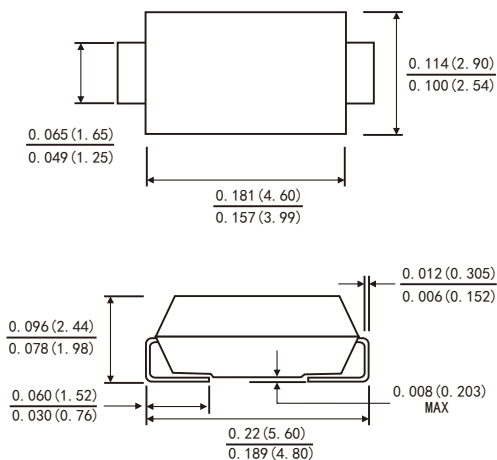

MECHANICAL DATA

- Case: JEDEC SMA(DO-214AC) molded plastic body
- Terminals: Solder Plated, solderable per MIL-STD-750,method 2026
- Polarity: Color band denotes cathode end
- Weight: 0.002ounce, 0.064 gram

TYPICAL APPLICATIONS

For use in low voltage ,high frequency inverters ,DC/DC converters, free wheeling ,and polarity protection applications

Suggested PAD Layout

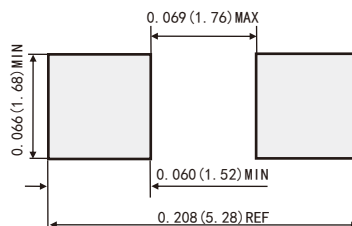

Dimensions in inches and (millimeters)

MAXIMUM RATINGS

(Ratings at 25°C ambient temperature unless otherwise specified)

Parameter	Symbol	Value	Unit
Maximum repetitive peak reverse voltage	V _{RRM}	40	V
Maximum average forward rectified current	I _{F(AV)}	3.0	A
Peak forward surge current 8.3ms single half sine-wave superimposed on rated load (JEDEC method at rated TL)	I _{FSM}	80	A
Operating junction temperature range	T _J	-55 to+150	°C
Storage temperature range	T _{stg}	-55 to+150	°C

RATINGS AND CHARACTERISTIC OF SS34L

ELECTRICAL CHARACTERISTICS (T_A=25°C Unless otherwise noted)

Parameter	Test Conditions		Symbol	TYP.	MAX.	Unit
Instantaneous forward voltage	I _F =3.0A	T _A =25°C	V _F ¹⁾	0.45	0.47	V
		T _A =100°C		0.39	-	
		T _A =125°C		0.37	-	
Reverse current	V _R =40V	T _A =25°C	I _R ²⁾	60	200	μA
		T _A =100°C		5	10	mA
		T _A =125°C		15	30	
Typical junction capacitance	4V, 1MHz		C _J	240		pF

Notes: 1.Pulse test: 300 μs pulse width, 1% duty cycle

2.Pulse test: pulse width ≤ 40ms

THERMAL CHARACTERISTICS

Parameter	Symbol	SMA	Unit
Typical thermal resistance ³⁾	R _{θJA}	88.0	°C/W
	R _{θJL}	28.0	

3.P.C.B. mounted with 0.2" x 0.2" (5.0 mm x 5.0 mm) copper pad areas

AVAILABLE PACK INFORMATION

Product code	Pack	Reel Size (mm)	Quantity (pcs/reel)	Box Size L×W×H (mm)	Quantity (reel/box)	Carton Size L×W×H (mm)	Quantity (box/carton)
SS34L-SMA	T/R	φ 330	5000	330×333×35	2	364×364×360	8

RATINGS AND CHARACTERISTIC OF SS34L

FIG.1-FORWARD CURRENT DERATING CURVE

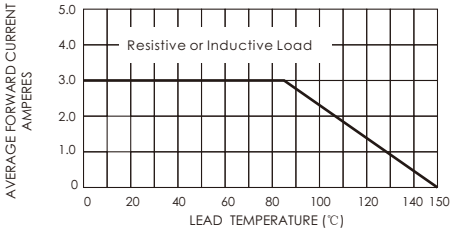

FIG.2-MAXIMUM NON-REPETITIVE PEAK FORWARD SURGE CURRENT

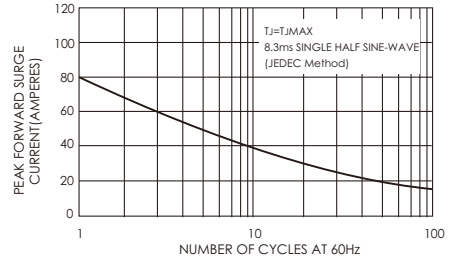

FIG.3-TYPICAL INSTANTANEOUS FORWARD CHARACTERISTICS

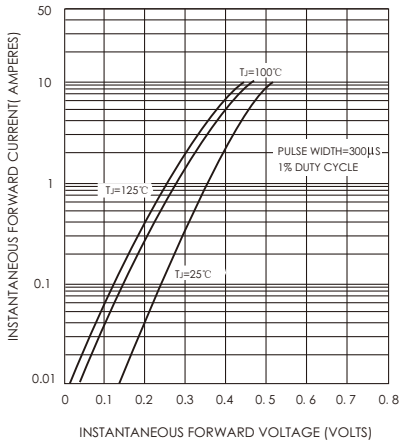

FIG.4-TYPICAL REVERSE CHARACTERISTICS

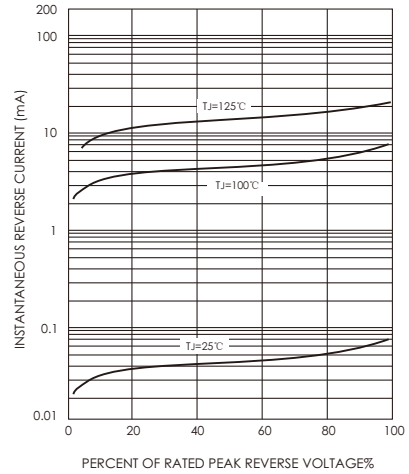

FIG.5-TYPICAL JUNCTION CAPACITANCE

